

Design and Development of IOT Based Pet Feeder

Pushpa Birha¹, Ruchika Ingle², Samruddhi Tajne³, Payal Mule⁴, Aanchal Pandey⁵,
Shivani Kukekar⁶, Aachal Kadu⁷

¹Asst. Prof. DEPT of CSE GHRIET Nagpur, India
²³⁴⁵⁶⁷Students of DEPT of. CSE GHRIET Nagpur, India

pushpa.birha@raisoni.net

Received on: 11 June ,2022

Revised on: 02 August ,2022,

Published on: 06 August,2022

Abstract – IOT technology to monitor and manage a component that is connected to the Internet. Pet Feeder is a feeding animal device and it has a network communication and could be remotely operated via a webpage. It works slightly differently than other pet feeder devices in that it follows orders from the owner via a webpage. The design of the device was divided into 2 parts: software and hardware. The software included IDE Arduino and ESP8266 Downloader, although the hardware included an arduino uno microcontroller, that also served as the device's brains, as well as ESP8266 devices, ultrasonic sensors, a stepper, a real-time clock, and a weight sensor.

.Keywords - Arduino, ESP8266, microcontroller

I – INTRODUCTION

Pets are now viewed as an important component of their owners' roles in human activities and lifestyles. The rise in the elderly population has resulted in an increase in the number of pets. A pet is frequently treated as if it were a member of the family. The most popular pets are dog and cat.

Each year , the animal care industry and business tends to grow, forcing the creation of new products with new technologies to help elderly people care for their pets. The presented machine's purpose is to make pet owners' life simpler and also to motivate them to raise their pets in a healthy manner. Each food's pet feeding must be considered carefully in order to increase a good health pet. If pets are not really fed on time, it does have a direct impact on pet's health. Poor nutrition, as well as a wide range of sicknesses, can consequence. As a result, this device will be a solution to the identified problem by

managing the feeding procedure via a mobile or desktop also. It includes features such as arranging pet feedings, establishing the pet's food for each food to reduce the risk of diseases, and so on.

II- LITERATURE REVIEW

This was a pet feeding apparatus that served the same purpose as ours in terms of feeding the pet.

However, the designer attempted to offer a new feature with this device, which was a pet collar that was used to track the whereabouts of the pet.

The primary downside is that it was designed for pets that spend most of their time at home, thus having a tracker makes no sense[1].

This gadget was created as an alternative to manual feeding in the form of an automatic feeding system.

The primary flaw we discovered with this device was that *it* relied on a web application to monitor and feed pets automatically. Because using a web application is not a viable option, our device includes an Android application that can be used from anywhere.[2]

The smart pet door was the first item in the pet monitor system, and it can assist the pet owner in controlling their pet's behavior. The smart pet feeder is the other device. The pet owner might schedule the pet eating bowl time remotely with the help of the technology. They have provided a pet door as a drawback, which may not be the best answer, but as an alternative, our equipment has a camera that is used for true monitoring.[3]

You can programmed the time and amount of food fed to your pet with an automatic pet feeder. Using specific

scales, based on who is missing, make progress. It is either forgotten or no longer necessary for them to feed their pets. The Internet of Things can also be used to monitor and record it (IoT). It also needs to be strong and long-lasting. To begin, the machine's operation is based on the food being stored in a silo with a screw conveyor feeding the pet's food [4].

III-METHODOLOGY

A. Designing State

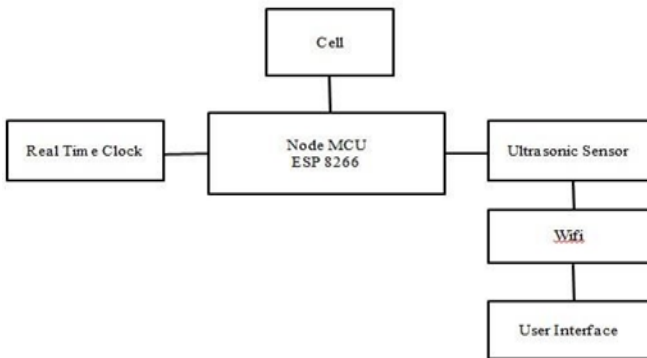

Fig - Architecture of IOT

The functioning principle of the tool will be discussed using the above block diagram. There are two ways to use the feeder. To begin, press the feed button that has been connected to the Arduino. The stepper motor will rotate when the feed button is pressed, and The distance between the sensor and the container will be monitored by the ultrasonic sensor. The stepper motor will move to open the food valve if it is more than 5 cm. The second option is to use a web server. When a web browser is used to access the IP Arduino displayed on the LCD, it will display the feeder's web display, which contains data such as the position of the stepper and the distance between the sensor and the food container, as well as a connection to feed the pets. The link is simply click when the stepper motor is moved to open the food valve when the distance between the sensor and the food container exceeds 5 cm.

The amount of food in the container will then be determined by the ultrasonic sensor. When the distance between the ultrasonic sensor and the food container is less than 5 cm, the stepper will move to close the food valve, as required by the regulations.

B. Hardware Designing

The design is used to connect all of the components and integrate them with a programme that was created to ensure that each component functions as intended. Each component's wiring can be seen in fig

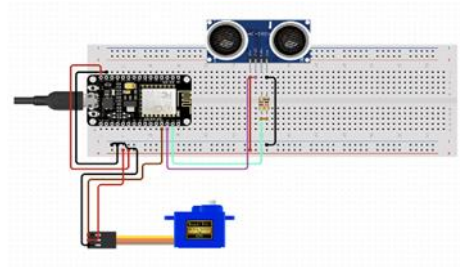

Fig 3.1-Circuit Diagram

C. Arduino:

The Arduino Uno is an open-source microcontroller which is using the Memory chips ATmega328P microcontroller established by Arduino. It can be operated by an Usb connection or a the outside 9-volt power supply and continues to operate at voltages ranging from 7 to 20 volts. This board will be



programmed with Arduino (IDE).

Fig- IOT Pet Feder Machine



Fig 3.2-Arduino

b. Ultrasonic Sensor:

An ultrasonic sensor is an electronic device that uses ultrasonic sound waves to measure the distance between a target object and converts the reflected sound into an electrical signal. Ultrasonic waves travel faster than audible sound waves.

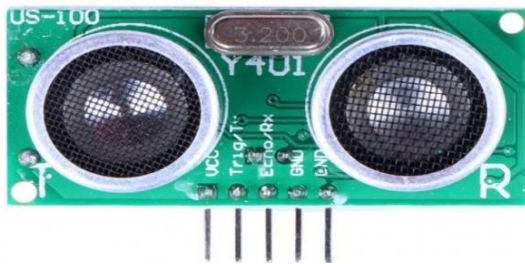

Fig 3.3.- Ultrasonic Sensor

c. Stepper motor:

A stepper motor divides a single full rotation into a series of much smaller (but essentially equal) part rotations. These can be used to instruct the stepper motor to move through specific degrees or angles of rotation for practical purposes.

IV- CONCLUSION

We created a mobile application for pet owners that serves as a conduit between the owner and their pets. The application is designed specifically for pet owners. We used engineering knowledge to analyse a societal problem that pet owners face when trying to feed their pets, and then devised a solution. During our project, we analyzed existing mobile apps related to pet feeders that assist them in feeding their pets and attempted to overcome their drawbacks in our project. To complete the project, we used the modern tool Android Studio.

V- RESULT

This is a IOT Pet Feeder machine we connected all the components in circuit board. Then provide power supply through the lithium battery transfer all the code in Arduino ESP 8266 from Arduino IDE. we have already defined weight and time for feeding but if we want to feed manually then go to the User Interface and click on feed button. we created two buttons in User Interface feed pet and reload feeder. when we click on feed button start feeding to the pets and machine. We used ultrasonic sensor for calculating distance between pet and machine it provides food only when sensor detecting footprint of pet in the range of 2-3 meters. we also already available in container then it not produces food it when we click on reload feeder button start reloading the produce only when container is empty. use weight sensor for calculating weight of food if food is available.

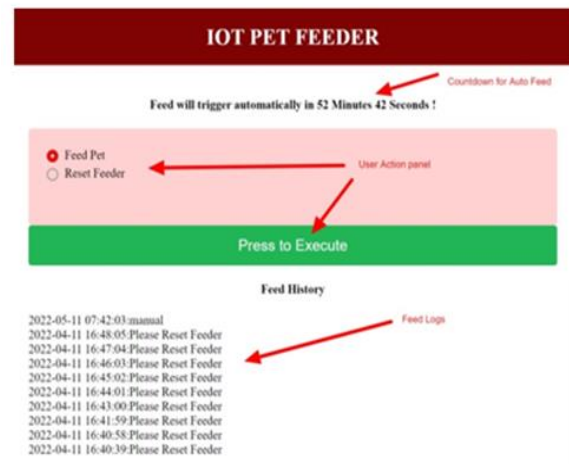

Fig – User Interface

VI- FUTURE SCOPE

We were able to merge the codes we had and also the components to work as one with a process that worked the way we wanted it to using the correct libraries and codes. We were able to create an Automatic Pet Feeder after a series of troubleshooting and code editing that dispenses food and water at the appropriate times to assist the owner in supporting and maintaining their pet's health and condition.

We can do a lot more to make our automatic pet feeder better. They can add more features to our Automatic Pet Feeder to conduct more research, such as an additional camera that allows the owner to see or monitor whether or not his or her pet is eating its meal. It will be even better if you add an RFID tag, because the pet will be able to eat at any time by approaching the automatic food dispenser.

REFERENCES

- [1] "Automatic Pet Monitoring and Feeding System Using IoT" was published by IJCR in 2017.
- [2] In 2016, the 2nd International Conference on Electrical Engineering (Icon-IEE) published "Design of Pet Feeder Using Web Server as Internet of Things Application."
- [3] "IoT Research and Applications in Pet Systems" This paper was published (<http://www.scirp.org/journal/ait>) and included Chinese students in 2019.
- [4] "Arduino-Based Automatic Pet Feeder" The International Journal of Innovative Research in Science published this paper. (IJIRSET) was published in 2018.
- [5] M. Pardo, L. G. Kwong, G. Sberveglieri, J. Schneider, W. R. Penrose, and J. R. Stetter, Detection of Contraband Food Products Using a Hybrid Chemical Sensor System, IEEE, 2021) 1073-1076.

- [6] K. Li, Z. Zhang, and W. Liu, *International Conference on Natural Computation, Automatic Test Data Generation Based On Ant Colony Optimization. Detection of Contraband Food Products with a Hybrid Chemical Sensor System*, W. R. Penrose and J. R. Stetter, *IEEE* (2021)
- [7] M Ibrahim, H Zakaria, EE Wei Xian, "Pet food auto feeder by using Arduino", *Materials Science and Engineering* 670 (2019), CADME 2019.