

Embedded Sensors in Work Clothing to Provide Health Data of Workers

Rituparna Ghosh¹, Ishwar S. Jadhav², Vijay D. Chaudhari³, Hemant T. Ingale⁴

¹PG (VLSI & Embedded System) student, 2,3,4Assistant Professor

^{1,2,3,4}E&TC Engg. dept, GF'S Godavari College of Engineering, Jalgaon - 425001

rituparnasinha3@gmail.com¹

ishwar.jadhav@rediffmail.com²

Received on: 10 January, 2023

Revised on: 05 February, 2023

Published on: 07 February, 2023

Abstract - Our work is related to a person safety using Arduino Uno. The person or mine worker are installed with sensors and WI-FI module. Gas sensor, temperature sensor, carbon dioxide sensor, and buzzer circuit also added in this project. The gas sensor is used to find the carbon level in the mine exhaust of the atmosphere and temp. sensor is using to find the operating condition are good or not for workers. If both are sensor value is not normal means the normal condition worker can work. Sensor is found in the position of the device, if the sensor value is abnormal or very high, means the value are sent local host at the same time buzzer will blow. Monitoring system the method and one thing we uploaded all values in local host.

Keywords: embedded sensors, work clothing, worker's health, Arduino Uno

I- INTRODUCTION

This consists of the safety purposes of the mine worker and here the sensor is used to monitor the atmosphere in mines. Abnormal values will activate the buzzer and the sensor value will be uploaded to the local host. Person tracking devices is not merely a decoration for safely purpose these days; it has emerged as indispensable requisite to safeguard against probable tribulations. Anyone who gives his life to risking for his work should assist personal assistance or for safety of his own environment, one is always burdened with uncertainty related to safe transit of persons/ passenger working in hazardous condition and hesitation about for long performance. This gave a jump start to introduce this wearable System which purposefully caters to

individual and organizational needs for mine safety of workers, monitoring and enabling to optimize workers performance in transit to work and save each life's resulting as a safety solution for everyone for reducing carbon footprints on earth.

II-LITERATURE REVIEW

Important process variables can be monitored from a distributed control system, as proposed in Tan, Lee, and Soh's (2002) study [1] [6]. This system would be hosted online (DCS). In order to get efficient remote access to the DCS's process variables, this study suggests hardware and software design considerations. Using one's voice to command one's household appliances to carry out a certain task [2][8] was proposed by Potamitis, Georgila, Fakotakis, and G. Kokkinakis, 2003. The methodology is slanted toward enabling persons with disabilities to carry out functional tasks at home by using their voices to control equipment. Through analysis of the speaker's voice, a voice separation approach is chosen. Using a system called "A System for Smart-Home Control of Appliances Based on Time and Speech Interaction," [3][9] developed by S. M. Anamul Haque, S. M. Kamruzzaman, and Md. Ashraf Islam in 2006, it is possible to manage your home's electronics from your computer. To create this system, we used Visual Basic 6.0 as our primary programming language and the Microsoft Voice Recognition SDK and Voice Editing SDK to implement our speech recognition functionality. Timers and voice commands both work for operating appliances. This paper presents the design and implementation of SMS-based control for monitoring systems [4][7], by Ciubotaru-Petrescu, Chiciudean,

Cioarga, and Stanescu (2006). There are three sections of this study that each use a sensor device to keep tabs on advanced software. A microcontroller serves as the brains of the operation, while a GPRS modem or a mobile phone's serial port RS-232 serves as the communication module. Status updates, such as a loss of power, can be sent through SMS. In 2008, [5][10] Jawarkar, Ahmed, Ladhake, and Thakare proposed voice-activated remote monitoring via cell phone. The microcontroller receives the spoken orders, converts them into text SMS, and sends them to the control system, where it makes a choice regarding a specific task based on the received text. (2015) "Remote Controlled Home Automation Using Android Application over WiFi Connectivity," [6][11] by Era Johri et.al.

III-PROBLEM STATEMENT

The technology was implemented based on their requirements. The following considerations were made

- (1) During work in the field what kind of environment they are exposed to? What to monitor?
- (2) Design of the sensor based of the area they are working in. What to measure?
- (3) Do the workers have some prior health issues or any handicaps?
- (4) How to ensure that the workers are using the sensors continuously?
- (5) Document feedback received from the worker regarding the sensors and make changes.

Proposed System

The purpose is to develop automation of IoT based security system with remote control via Internet and Android phone. As technology advances, industries also become adaptive. New age factories are generally moving from old switches to unified control arrangements, for this RF based switches are used. Currently, remote-based IoT automation monitoring system provides an easier alternative to use with Radio Frequency based technology. To do this, the remote that interfaces with the Android app with Wi-Fi active on the transmitter side sends a data signal to the receiver to which the PC is connected.

Methodology

During this research we first conducted an assessment of the workers preferences and handicaps. There are many aspects that can hinder the application of this technology. For successful implementation of this sensor-technology in the work place it must meet multiple criteria. The most important information to

keep in mind is the need of the employees working in the fields.

As at the transmitter in figure 1, the digital code for current detected for every room is detected and a different RF signal is generated and send in atmosphere. Then at receiver this signal is received & according to the assigned code & names will be displayed on the display. All other function will be performed by microcontroller.

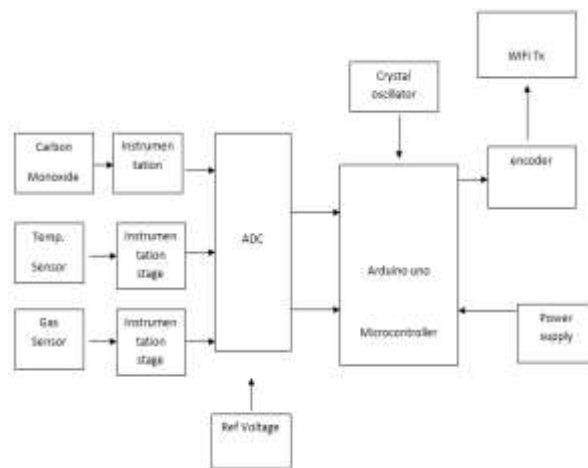

Fig.1- Transmission station

Carbon Monoxide Sensor:

This is a electrochemical sensor. It is highly accurate in reading the carbon monoxide value and it is very sensitive. The is in terms of the change in current flowing in the circuit.

Instrumentation Stage:

This is essential as the output from the sensor is not in the form of voltage, so it needs to be amplified and converted to the voltage form. The output needs to calibratealso. The output voltage needs to be proportional to the correct carbon monoxide value.

WIFI transmitter-

Code for every person is set differently. It consists of code generating logic circuit. The desired code for that parameter is set while designing.The desired code and data that is to be send is encoded by the encoder circuit. The encoder sends the code serially to the RX Tx module. The RX Tx module sends the code by using ASK type of modulation and the carrier of 2.5 MHz

WIFI Receiver –

This is receiver stage will receive the different code and data which are transmitted by the transmitter stage this will provide strong signal to the detector stage. Also

suppressed noise level. ASK modulated signal is demodulated this signal is provided to detector stage.

Data detector-

this data detector will detect the signal to a code this decoded code is provide to the microcontroller according to the received code the detected signal is send to the microcontroller.

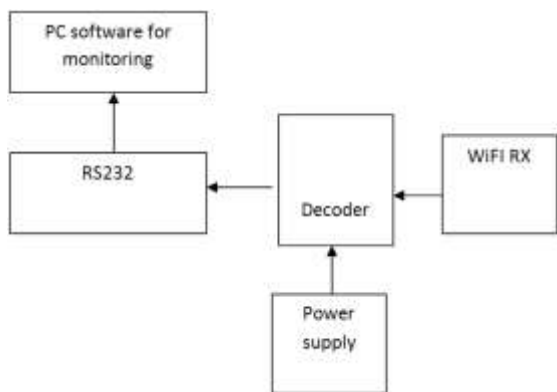

Fig. 2- Central monitoring station

Receiver section includes components like WIFI receiver; decoder; ATMEGA; relay; load driver stage fig. 2. The WiFi receiver and decoder are linked here in the receiver. Connected between the microcontroller and the transistor driver stage is this decoder. This driver links up with the relay, which in turn links up with various loads.

resulting as a safety solution for everyone for reducing carbon footprints on earth. In big mines and all B and C grade mines now a day’s only one problem becoming very critical that is environmental parameters in many areas of the mines there is very many parameters and in some area, there is less parameters so where there is more parameters it needs to monitored and try to find solution to control it. For that same reason this system is introduced which is very important, Because this system is a standalone system with a feature that it can be installed anywhere in the mines and the parameter monitoring department of company can keep track of the reading coming from all the area say if we installed with worker system the mines then it can be monitored and one can know where is more parameters and where is less parameters and if there is more parameters in some areas then one can make provision such as banning the vehicle from going to that area or banning only heavy vehicles from this area likewise action can be taken. It will save a lot of energy and time for the installation department to read the situation and take some action, it will also save manpower by sending man to specific place and ask him We monitor the readings of the mobile monitoring device for the whole day of heavy exercise. That is why this system is essential for anyone working in the mines. In the future, more sensors can be combined to read other parameters in this system such as noise parameters, air density, visibility.

IV-SCOPE OF RESEARCH

Participants identified five requirements for using sensor technology at workplaces. The dimensions of sensor technology implementations, the durability of the sensors, corporate commitments and laws, and the intrusiveness and privacy of workplace feedback.

Dimension and Heft of The Sensors

People using the sensors noted that the overall dimensions of the sensors can cause problems during its use in the field. Based on the feedback we found that the sensors must not hinder the ability of the workers to perform their tasks. Additionally, the workers requested that the weight of the sensors should be manageable so that dusting various tasks it should not get in their way of hamper the outcome of the task.

Durability of the Sensors

Durability of the sensors is the most important aspect for long terms success and implementation of the sensors in the work place. The work place can have dirt, fumes, radio signals which interfere with the sensors. It



Fig. 3- Safety purposes of the mine worker

This gave a jump start to introduce this wearable System fig. 3 which purposefully caters to individual and organizational needs for mine safety of workers, monitoring and enabling to optimize workers performance in transit to work and save each life’s

can get wet or be exposed to extreme heat. It must withstand all these conditions and still function while providing accurate data regarding the worker.

Company Goals and Rules

Different companies have different rules for the work place. Many companies have stipulations regarding various gadgets a worker can carry into the work place. For example, most companies now a days do not allow smart phones in the workplace. In addition, the application of sensor technology must correspond to the standards of the (local) company.

Time Commitment

Users of the sensors wanted the implementation to consume less time, so that they can be efficient at the work place. For example, the users wanted a simple interface so that they were not forced to change the setting multiple times. They wanted clear instructions on how to wear the sensors and use them. The device needed to be simple so that no extra training would be required to operate it, plus they can use it simultaneously along with their work.

Motivating Users to Continuously Wear the Sensors

Three facets of the technology were reported to be necessary for motivating or impeding the long term use of the sensors: (1) workload measurement and monitoring; (2) data security and clarity of data ownership; and (3) user reviews.

Data Collection During Work Hours

Users wanted to know about the different data being collected about their physical health and work habits. This would allow them to make changes or take precautions to avoid injury to health. "For example, recognizing physical stress and what you can do about it."

Privacy of Data and Access to Data

User wanted direct ownership of the data collected and wanted to make their own decisions regarding sharing of data. "Give the data to the workers, they can then give it to the needed person or the requester." In addition, the participants indicated that data could be shared. Example: General Practitioners (General Practitioners) will be allowed access to the health data of the workers. "When I declare that my GP may receive my results after health check, that's fine with me". Participants also approved of the health and safety measures taken by their own company health departments, but they were hesitant about the conflict of interest. Users were ready to share their health data with their employers on a need to know basis. The data

would be shared temporarily and deleted after use. "I believe if you do it work-related, such as lifting, it is accessible to employers. Things like heart rate are a bit more personal."

V- RESULT AND DISCUSSION

This study provides an insight in to the needs and like of the workers who operate in physically laborious jobs and how technology can be used to ensure their safe and increase efficiency at the same time. The participant categorized three workloads (physical workload, jobs with high exposure to heat and stress and jobs with high levels of noise) and one health hazard (tiredness) that she wanted to measure with the sensor technology application. The application of sensors fig.4 combined with the clothing and wearable devices was preferred the users. This made it easy to collect data during work hours and the exposure of the workers to the environment.

The biggest stipulation on the data collection was that it must be delivered to the workforce in real time without any lag but also must be monitored in a centrally located office.

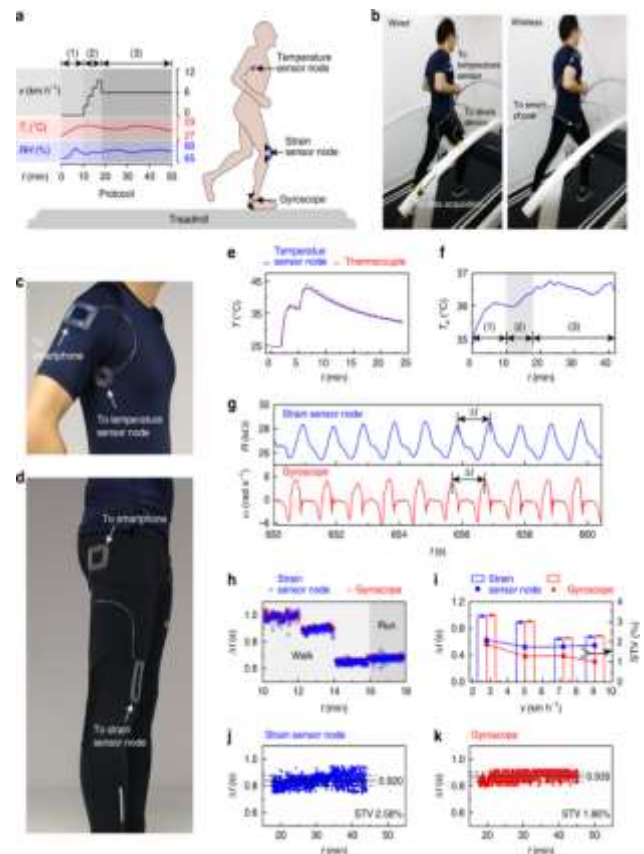

Fig. 4- Health regulation analysis

In case of an emergency data must be sent to the user immediately. fig. 5 When this sensor is used on the workers during office hours it must comply with corporate rules and health regulation provided by the government. fig. 6 As an added bonus it must be comfortable to wear for long hours. To make sure that the technology is widely accepted and implemented it must function safely, it should be able to handle extreme work conditions and users must have independent control over distribution of the data. Users preferred to have real time feedback to avoid any major accidents. Users were a little sceptical about sharing health data with their employers. But in the interest of goodwill they agreed to share the data temporarily with the concerned authorities.



Fig. 5- Parameter sensed data



Fig. 6 Variation in sensed data

VI- CONCLUSION

The application of sensor technology helps workers in physically demanding jobs measure and monitor their work exposure. Hurdles to implementing the sensors, like data-privacy concerns, quality, convenience, and easy of use, must be carefully taken in to account for the successful assimilation of the sensor based health monitoring systems in the work place for a long period of time. Safety and health incredibly important at the workplace. Employee work conditions are of paramount importance to the companies. To take care of

productivity within the post pandemic era it's important to supply security to people. the price of health care is rising; hence prevention is cheaper than the value of cure. In this regard sensors based monitoring systems help companies keep track of a healthy work environment. It also helps in minimizing risks to the workers. Because of this awareness among the companies to keep people safe at their place of work there is a rising trend of wearable technology such as smart watches, bands and other such devices. These help the company in monitoring situation awareness of the worker, avoid injury risks and make the work flow efficient. It has helped companies maintain healthy behavior amongst its employees and help worker become more cognitive. Current generation monitoring systems are geared towards monitoring physical aspects of the workers. But new generation systems are being created to monitor the overall psychological health of the people at the work place. These systems are being designed to monitor anger, depression or mood swings of the workforce. These newer systems will provide wide scope to manufactures to produce devices in large quantities to identify and number of occupational hazards and pitfalls. But to ensure wide spread adaptation of these devices, manufactures must conduct third party testing using independent contractors. This research is aimed at helping the manufactures to created monitoring sensors, using the feedback collected through this study. It will help manufactures to bridge the gap between the expectation of their customers and the design of the sensors and its implementation.

REFERENCES

- [1] Tan, Lee, " Internet-based monitoring of distributed control systems-An undergraduate experiment", DOI:10.1109/TE.2002.1013876, IEEE Transactions on Education 45(2):128 - 134, Jun 2002.
- [2] Potamitis, I., Georgila, K., Fakotakis, N., & Kokkinakis, G. (2003). An integrated system for smart-home control of appliances based on remote speech interaction. EUROSPEECH 2003, 8th European Conference on Speech Communication and Technology, pp. 2197-2200, Geneva, Switzerland, Sept. 1-4, 2003.
- [3] S. M. Anamul Haque, S. M. Kamruzzaman, Md. Ashrafal Islam, " System for Smart-Home Control of Appliances Based on Timer and Speech Interaction", Proceedings of the 4th International Conference on Electrical Engineering & 2nd Annual Paper Meet 26-28 January, 2006. pp. 128-131.
- [4] Ciubotaru-Petrescu, B., Chiciudean, D., Cioarga, R., & Stanescu, D. (2006). Wireless Solutions for Telemetry in Civil Equipment and Infrastructure

Monitoring. 3rd Romanian-Hungarian Joint Symposium on Applied Computational Intelligence (SA CI) May 25-26, 2006.

- [5] *Jawarkar, Ahmed, Ladhake, and Thakare, "Micro-controller based Remote Monitoring using Mobile through Spoken Commands", JOURNAL OF NETWORKS, VOL. 3, NO. 2, FEBRUARY 2008, pp. 58-63.*
- [6] *Era Johri, Pradnya Bhangale et.al. " Remote Controlled Home Automation Using Android Application via WiFi Connectivity", International Journal on Recent and Innovation Trends in Computing and Communication ISSN: 2321-8169 Volume: 3 Issue: 3, pp. 1489-1492.*
- [7] *Da Costa BR, Vieira ER. Risk factors for work-related musculoskeletal disorders: a systematic review of recent longitudinal studies. Am J Ind Med. 2010;53(3):285–323.*
- [8] *Andersen LL, Fallentin N, Thorsen SV, Holtermann A. Physical workload and risk of long-term sickness absence in the general working population and among blue-collar workers: prospective cohort study with register follow-up. Occup Environ Med. 2016;73(4):246–53.*
- [9] *Sundstrup E, Hansen AM, Mortensen EL, Poulsen OM, Clausen T, Rugulies R, Moller A, Andersen LL. Retrospectively assessed physical work environment during working life and risk of sickness absence and labour market exit among older workers. Occup Environ Med. 2018;75(2):114–23.*
- [10] *O'Reilly D, Kumari M, Batty GD, Ferrie JE, Virtanen M, IPD-Work Consortium. Long working hours and risk of coronary heart disease and stroke: a systematic review and meta-analysis of published and unpublished data for 603,838 individuals. Lancet. 2015;386(10005):1739–46.*
- [11] *Alavinia SM, van den Berg TI, van Duivenbooden C, Elders LA, Burdorf A. Impact of work-related factors, lifestyle, and work ability on sickness absence among Dutch construction workers. Scand J Work Environ Health. 2009;35(5):325–33.*