

Modal and Harmonic Analysis of CNC Milling Machine Bed using Composite Material

Mrs. Vibha¹, Dr. Lokesh Singh², Mr. Chandrabhushan Tiwari³

¹M.Tech Student, Department of Mechanical Engineering, GDR CET Bhilai, Chhattisgarh, 490024

²Assistant Professor, Department of Mechanical Engineering, GDR CET Bhilai, Chhattisgarh, 490024

³Assistant Professor, Department of Mechanical Engineering, GDR CET Bhilai, Chhattisgarh, 490024

Abstract: The materials utilized as a part of a machine device have an unequivocal part in deciding the efficiency and exactness of the part made in it. The regular basic materials utilized as a part of exactness machine apparatuses, for example, cast iron and steel at high working velocities create positional mistakes because of the vibrations moved into the structure. Quicker cutting rates can be procured just by structure which has high firmness and great damping attributes.

The life of a machine is inversely proportional to the levels of vibration that the machine is subjected. The further procedure is completed to experience the distortion, normal recurrence and removal utilizing Static examination, Modal investigation and Harmonic individually. Since the bed in machine apparatus assumes a basic part in guaranteeing the exactness and precision in segments. Is a standout amongst the most critical apparatus structures which have a tendency to retain the vibrations coming about because of the cutting operation. To break down the bed for conceivable material changes that could build solidness, diminish weight, improve damping characteristics.

In this paper constant load is applied on a bed made with composite materials. Aluminium Silicon Carbide (Al-SiC) is used as composite material basing on strength and thermal properties. Modelling of the bed was carried out in 3DCAD and ANSYS is used for structural analysis.

Key words: Machine Bed, Model analysis, Harmonic Analysis, ANSYS Benchwork

I- INTRODUCTION

The transfer of high speed as well as the high cutting speed of machine tools is very essential important for the improvement of productivity. The deformation of machine tool structure under cutting forces and loads which leads to the poor quality of products with less accuracy, both dimensional as well as geometrical of the product.

Along these lines, the level of twisting and vibration that decides the segments with high exactness. Obviously, the lifetime of a machine is conversely relative to the level of vibration that the machine is subjected.

The further process is carried out to under goes the natural frequency and displacement using Modal analysis and Harmonic analysis respectively. To analyse the bed for possible material changes that could increase stiffness, reduce weight, improve damping characteristics and isolate natural frequency from the operating range.

At present the Machine Beds are made of grey Cast Iron material, which cause a number of problems in Machine tools. Cast Iron cannot with stand the sudden loads during operation whenever the load reaches Ultimate loads it simply fails without any prior indication.

Modal analysis is a technique to study the dynamic characteristics of a structure under vibrational excitation. Natural frequencies, mode shapes and mode vectors of a structure can be determined using modal analysis. Modal analysis allows the design to avoid resonant vibrations or to vibrate at a specified frequency and gives engineers an idea of how the design will respond to different types of dynamic loads. The machine bed is one such structure whose dynamic characteristics can be better studied by modal analysis.

The objective of this study is to determine the natural frequencies. The modal and harmonic response has been carried out in Finite Element package ANSYS Workbench 15.0.

II. LITERATURE REVIEW

A.Selvakumar, P.V. Mohanram [1] shows that Structure material plays a vital role in precision machine tools, which are expected to produce the parts within the specified accuracy of shape and dimensions together with the required surface finish. The shape of the work piece depends on the instantaneous relative position of the tool and the work piece and, therefore, of the machine parts which carry them. Hence, a structure which possesses high structural stiffness and high damping is to be selected. Composite materials such as, epoxy granite, exhibit good mechanical properties such as high stiffness and damping ratio at a lesser weight, compared to conventional materials. However, for the same stiffness, the basic dimensions of the structures vary. S. Syath Abuthakeer [2] proposed how to improve static and dynamic characteristics on a CNC machine. Simulation results show that the static and dynamic performances of vertical ribs with hollow bed have been improved. Structural vertical ribs with hollow offers a method to improve the conventional design of machine structure. Based on structural modifications, ribs parameters and distributions can be further optimized.

A. Merlo [3] analyzed the combination of hybrid materials (steel, CFRP, Al honeycomb) and an intensive use of gluing technology allows to increase damping and, at the same time, to get a consistent mass reduction (up to 40%) without reducing the overall stiffness.

III. MATERIAL

Composite materials are engineering materials made from combination of two or more material with significantly physical or chemical properties and which remain different on a macroscopic level with in the finished structure. There are several reasons to adopt the interest in metal- matrix composites as composite material, the most important one being their engineering properties. MMCs are of light weight, and good stiffness and low specific weight. It is generally considered that these materials offer savings in weight, at the same time maintaining their properties. MMCs also have other advantages as well, like strength, fracture toughness, thermal stability, and ductility and enhanced elevated temperature performances. However, cost remains a major point of interest for commercial applications of MMCs in future. Rapid development in MMCs has been

recorded in the past few years, but these have not been cost conscious efforts. More recently, reduction in processing costs; costs of raw material and the desirability of special properties have generated a great amount of interest.

IV. MACHINE BED

The machine bed has a vital role in providing rigidity and strength of machine. Its design is crucial for the accuracy and performance of the machine tool where it boards all the accessories, tools and other equipment for running of the machine. It is the one happened to subjected to various dynamic and static forces during the machine operation.

Machine Bed supports all the elements like a column, worktable and servo engines. The cutting power which is prompted in the machining procedure is essentially changed to machine bed, and machine beds retain the vibrations instigated in the machining procedure. The machine bed contains a hole for bracing lead screw which drives the worktable. Therefore that workpiece can be moved as per the user programming code.

And likewise bolsters the segment on the machine bed backside with the assistance of lead screws. Machine beds withstand the different powers produced amid the cutting. Accurate products will be produced only when the machine bed has high structural stiffness and good damping characteristics. So that the two major design factors structural stiffness and damping coefficient considered while designing the machine bed.

Whenever machining operation starts machine bed experiences cutting forces. Those forces can be divided into three types, they are the tangential cutting force, feed force and radial force.

The loads applied to the machine bed are calculated as.

Total weight of Machine = 170 Kg.

The load acting on the rear end of Machine Bed = 73Kg.

The weight of the Work Table = 18Kg.

Total forces acting on guideways = cutting force + Weight of work table and workpiece
 $= 95 + (18 \times 9.81)$
 $= 272 \text{ N}$

Force due to other accessories = $73 \times 9.81 = 717 \text{ N}$

All the above-calculated loads are applied on the Machine bed during the analysis of the machine bed.

V. METHODOLOGY

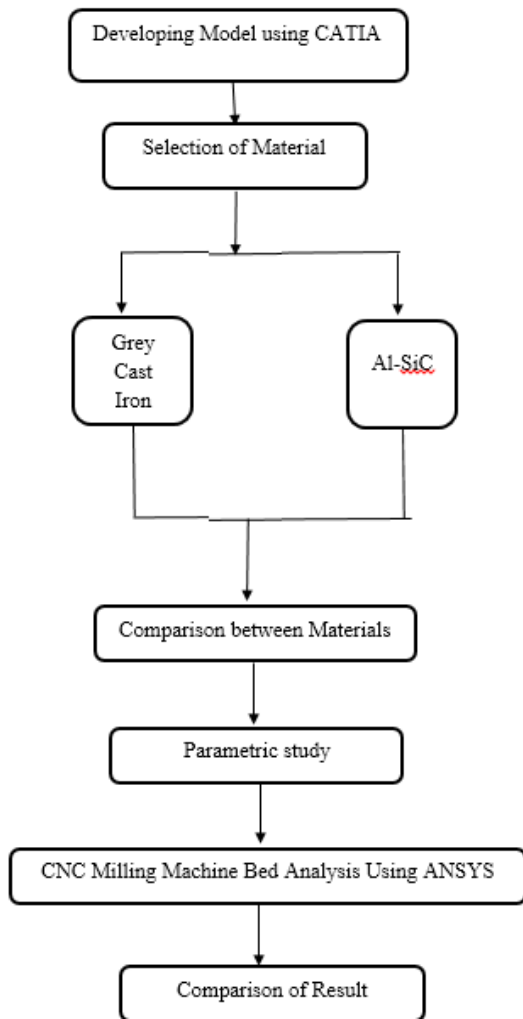

Fig.1:- Flow chart of dissertation execution

VI. MODELING AND ANALYSIS

A 3D model of the CNC machine bed was created in the CATIA V5 R20 software and saved in the iges format and importing in to Ansys work bench. The analysis was carried out on three materials cast iron, stainless steel and HM CFRP. In this stage Force and displacement boundary condition were applied as follows forces, front end of the machine bed carries cutting force, weight of the work table and weight of the work piece, due to this a total load of 272 N is applied on the Guide ways of Machine bed. Rear end of the Machine bed carries vertical column, and other accessories (ie servo motors, spindles etc.), due to this a total load of 717N will be applied on two flat surfaces of rear end.

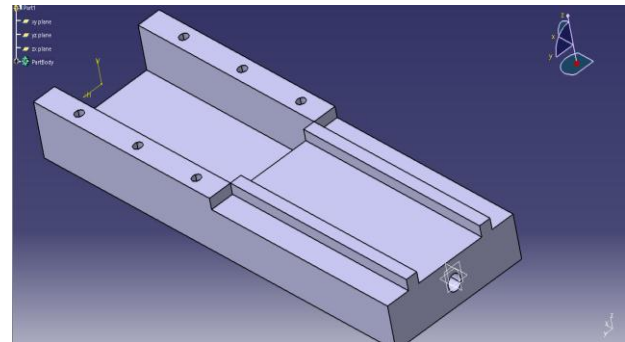

Fig.2:- Machine Bed Model in CATIA

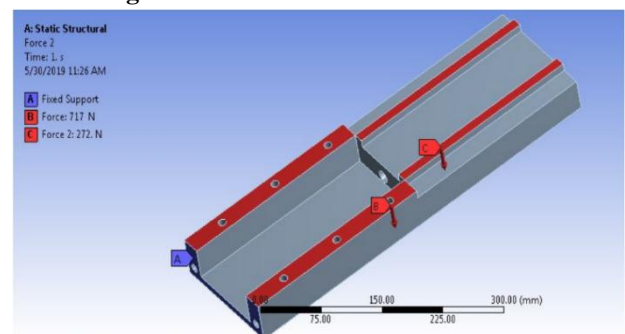

Fig.3:- Forces applied on the machine bed

Harmonic Analysis:

1. Grey cast iron:

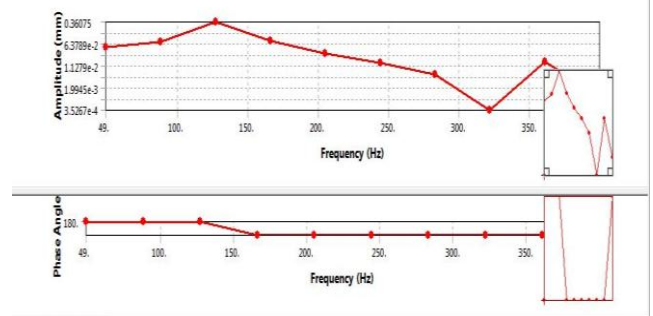

Fig.4:- Harmonic Analysis of Grey Cast Iron

2. Al-SiC

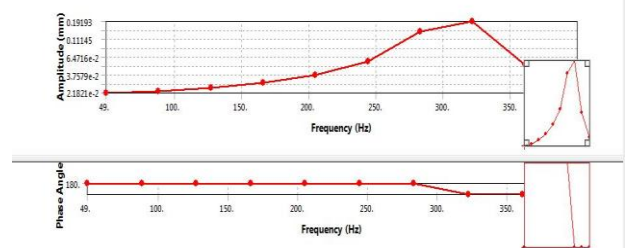

Fig.5:- Harmonic Analysis of Al-SiC

VII. RESULTS AND DISCUSSION

Modal Analysis: Result obtained from modal analysis is shown in table and graph:

Table.1:- Comparison of Modal Analysis Results

Mode	Frequency (Hz)	
	Grey Cast Iron	Al-SiC
1	135.29	360.28
2	258.14	584.35
3	303.51	680.35
4	341.87	766.15
5	410.59	919.88
6	491.84	1117

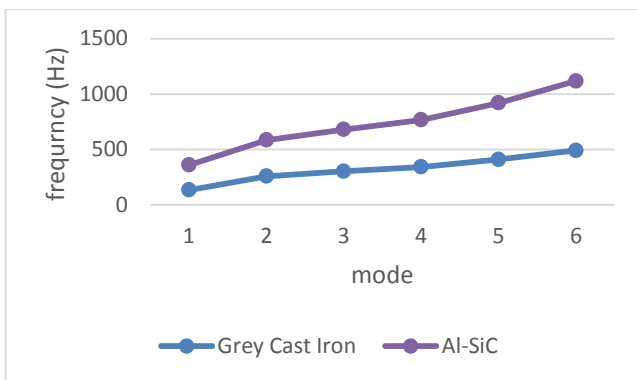

Fig.6:- Comparisons of results for material frequencies

In the modal analysis natural frequencies are obtained and from the fig.6.1: Comparisons of results for material frequencies (graph), it shows that natural frequencies are higher for Al-SiC than Grey Cast Iron and other composite materials.

Harmonic analysis:

Result obtained from harmonic analysis is tabulated below:

	Frequency	Amplitude	
		Grey Cast Iron	Al-SiC
1	49	5.1032e-002	2.1821e-002
2	88	7.5936e-002	2.3125e-002
3	127	0.36075	2.5532e-002
4	166	8.1753e-002	2.9786e-002
5	205	2.9852e-002	3.7857e-002
6	244	1.4927e-003	5.6714e-002

7	283	5.6606e-003	0.14016
8	322	3.5267e-004	0.19193
9	361	1.5105e-003	5.1033e-002

Table.2:- Comparisons of result for harmonic analysis

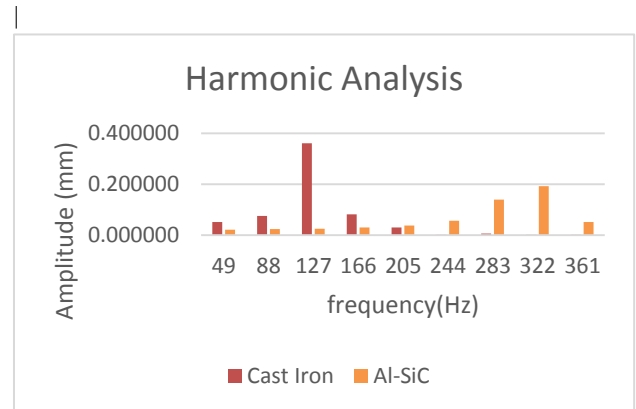

Fig.7:- Comparison for Maximum Amplitude

From the harmonic analysis table the resonance frequency are identified for all the materials considered in this work. The responses for grey cast iron and other composite material lathe bed at their corresponding resonance frequencies are shown in the table 2.

VIII. CONCLUSION

It is observed that Grey Cast Iron have high amplitude of response and Al-SiC have low amplitude of response.

1. For The harmonic analysis is carried out resonance frequencies for all the materials of machine bed.
2. For Grey Cast Iron maximum amplitude value obtained is 0.643 mm at frequency 166 Hz.
3. For Al-SiC maximum amplitude value obtained is 0.19 mm at frequency 322 Hz.

It is observed that Al-SiC have high resonance point that compared all composite material.

REFERENCE

[1] A.Selvakumar, P.V. Mohanram, "Analysis of alternative composite material for high speed precision machine tool structures" International journal of Engineering, 2012.

[2] S. Syath Abuthakeer, P.V. Mohanram, G. Mohan kumar, "Structural redesigning of a CNC lathe bed

to improve its static and dynamic characteristics”, International journal of Engineering, 2011.

- [3] Merlo, D. Ricciardi, A. Cremona, F. Meo, F. Aggogeri, “Advanced composite materials in precision machine tools sector – Applications and perspectives”, 2013.
- [4] Anil Antony Sequeira, “Modified Approach for Cutting Force Measurement for Face in Milling”, *Innovative Systems Design and Engineering*, 2012.
- [5] S. Kalpakjian, *Manufacturing Engineering and Technology*, 3rd Edition, Addison-Wesley, Reading, MA, 1995.
- [6] K Karvanis, et.al, “Production and mechanical properties of Al-SiC metal matrix composites” 2016
- [7] Jung Do Suha, Seung Hwan Changa et.al, “Damping characteristics of composite hybrid spindle covers for high speed machine tools”, *Journal of Materials Processing Technology*, 2001.
- [8] M.Govindan, et.al, “Design and Analysis of Automobile Brake Disc by Using Al/SiC MMC”, 2017.