

A Review of Solar Collectors in Solar Thermal Applications

Kartik Somalwar

Department of Mechanical Engineering ,G.H. Rasoni College of Engineering, Nagpur, India

Abstract - Thermal applications are drawing increasing attention in the solar energy research field, due to their high performance in energy storage density and energy conversion efficiency. This paper focuses to provide a detailed review on solar collectors and its different types. Various types of solar collectors are reviewed and discussed, including both non-concentrating collectors (low temperature applications) and concentrating collectors (high temperature applications) as well as system configuration is also reviewed.

INTRODUCTION

The Sun releases an enormous amount of radiation energy to its surroundings: 174 PW (1 PW = 10^{15} W) at the upper atmosphere of the Earth. When the energy arrives at the surface of the Earth, it has been attenuated twice by both the atmosphere (6% by reflection and 16% by absorption) and the clouds (20% by reflection and 3% by absorption) as shown in fig.

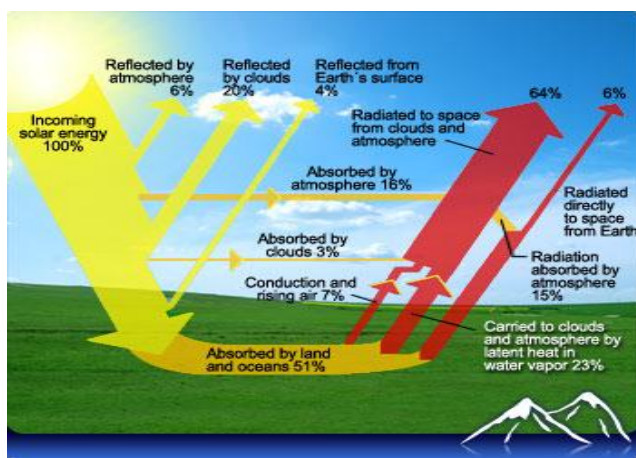

Fig.1- The Earth's energy budget

Another 51% (89 PW) of the total incoming solar radiation reaches the land and the oceans. It is evident that, despite the attenuation, the total amount of solar energy available on the Earth is still of an enormous amount, but because it is of low-density and intermittency, it needs to be collected and stored efficiently. Solar collectors need to have good optic performance (absorbing as much heat as possible) and good long-term durability. A solar thermal collector collects heat by absorbing sunlight. A collector is a device for capturing solar radiation. Solar radiation is energy in the form of electromagnetic radiation from the infrared (long) to the ultraviolet (short) wavelengths.

2. Solar collectors

A solar collector, the special energy exchanger, converts solar irradiation energy either to the thermal energy of the working fluid in solar thermal applications, or to the electric energy directly in PV (Photovoltaic) applications. For solar thermal applications, solar irradiation is absorbed by a solar collector as heat which is then transferred to its working fluid (air, water or oil). The heat carried by the working fluid can be used to either provide domestic hot water/heating, or to charge a thermal energy storage tank from which the heat can be drawn for use later (at night or cloudy days). For PV applications, a PV module not only converts solar irradiation directly into electric energy (usually with rather low efficiency), but it also produces plenty of waste heat, which can be recovered for thermal use by attaching PV board with recuperating tubes filled with carrier fluids.

Solar collectors are usually classified into two categories according to concentration ratios non-concentrating collectors and concentrating collectors. A non-concentrating collector has the same intercepting area as its absorbing area, while a sun-tracking concentrating solar collector usually has concave reflecting surfaces to intercept and focus the solar irradiation to a much smaller

receiving area, resulting in an increased heat flux so that the thermodynamic cycle can achieve higher Carnot efficiency when working under higher temperatures.

3. Non-concentrating collectors

3.1 Flat plate collectors

Flat-plate collectors, developed by Hottel and Whillier in the 1950s, are the most common type. Flat-plate solar collectors are usually permanently fixed in position, and therefore need to be oriented appropriately. A typical flat-plate solar collector usually consists of glazing covers, absorber plates, insulation layers, recuperating tubes (filled with heat transfer fluids) and other auxiliaries. Glazing is made of single or multiple sheets of glass or other materials with high transmissivity of short-wave radiation and low transmissivity of long-wave radiation. It not only reduces convection losses from the absorber plate, but also reduces irradiation losses from the collector due to the greenhouse effect. Low-iron glass is regarded as a desirable glazing material due to its relatively high transmittance for solar radiation (approximately 0.85–0.87) and an essentially zero transmittance for the long-wave thermal radiation ($5.0 \mu\text{m} - 50 \mu\text{m}$). Hellstrom et al. studied the impact of optical and thermal properties on the performance of flat-plate solar collectors, and found that adding a Teflon film as second glazing increased overall performance by 5.6% at 50°C , while installing a Teflon honeycomb to reduce convection loss increased overall performance by 12.1%. Further, antireflection treatment of the glazing cover increased the output by 6.5% at 50°C operating temperature.

The absorber plate is usually coated with blackened surface in order to absorb as much heat as possible. Desirable selective surfaces usually consist of a thin upper layer, which is highly absorbent to shortwave solar radiation but relatively transparent to long-wave thermal radiation, and a thin lower layer that has a high reflectance and a low emittance for long-wave radiation. Such selective surfaces with a desirable optical performance usually have a high manufacturing cost, but several low-cost manufacturing ideas have also been proposed. In addition, to further improve the thermal performance of a collector, heat loss from the absorber also needs to be reduced, transparent material placed in the airspace between the glazing and the absorber, was beneficial to heat loss reduction. The heat absorbed by the absorber plate needs to be transferred to working fluids rapidly to

prevent system overheating. Excellent heat transfer performance is necessary in solar receivers.

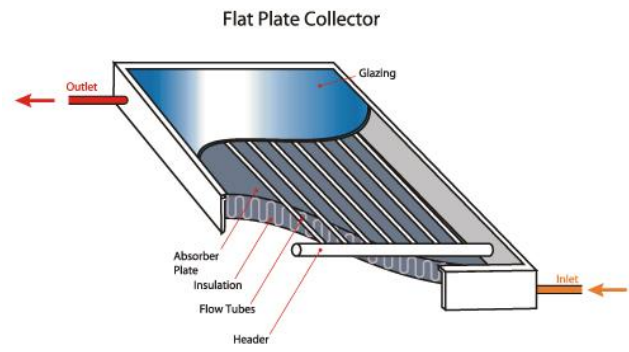

Fig.2. Flat plate collector

3.2. Evacuated tube collectors

This type of solar collector consists of two main parts: vacuum pipes and the manifold. Along the manifold a set of vacuum pipes are installed. Particularly, each vacuum pipe consists of an inner tube and an outer tube; between them the vacuum is created to enhance the thermal features of the collector, decreasing thermal losses.

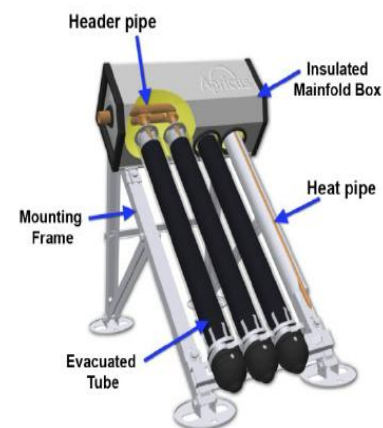

Fig.3. Evacuated type solar collector

There are two typologies of pipes: direct flow or heat pipe. The first has similar working principles to the collectors described before. Indeed, within the vacuum pipe there is an absorber sheet with tubes embedded, where the working fluid circulates. Instead, the second has a different operating principle: each vacuum pipe contains a fluid which evaporates, when heated up by solar radiation. Then, the vapour goes up in the manifold, where,

condensing, it releases latent heat to the system working fluid.

4. Concentrating collectors

4.1. Heliostat field collectors

The Heliostat Field Collector, also called the Central Receiver Collector, consists of a number of flat mirrors/heliostats. Due to the position change of the sun during the day, the whole array of mirrors/heliostats needs to have precise orientation to reflect incident solar lights to a common tower. The orientation of every individual heliostat is controlled by an automatic control system powered by altazimuth tracking technology. Each Heliostat collector at a central receiver facility has from 50 to 150 m² of reflective surface, with four mirrors installed on a common pillar for economy, as shown in Figure.

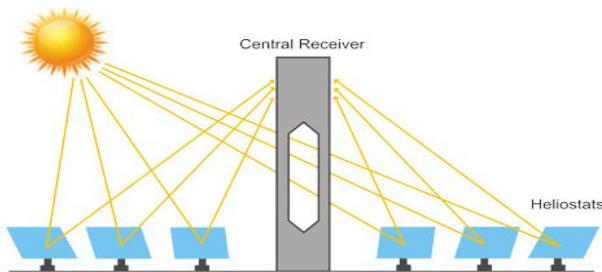

Fig.4.Heliostat solar collector

The heliostats collect and concentrate sunlight onto the receiver, which absorbs the concentrated sunlight, transferring its energy to a heat transfer fluid. The heat transport system, which consists primarily of pipes, pumps, and valves, directs the transfer fluid in a closed loop among the receiver, storage, and power conversion systems. A thermal storage system typically stores the collected energy as sensible heat for later delivery to the power conversion system. The storage system also decouples the collection of solar energy from its conversion to electricity. The power conversion system consists of a steam generator, turbine generator, and support equipment, which convert the thermal energy into electricity and supply it to the utility grid.

4.2. Parabolic trough collectors

A parabolic trough is a type of solar thermal collector that is straight in one dimension and curved as a parabola in the other two, lined with a polished metal mirror. The energy of sunlight which enters the mirror parallel to its plane of

symmetry is focused along the focal line, where objects are positioned that are intended to be heated. Parabolic trough collectors can concentrate sunlight with a concentration rate of around 40, depending on the trough size. The focal line temperature can be as high as 350 °C to 400 °C.

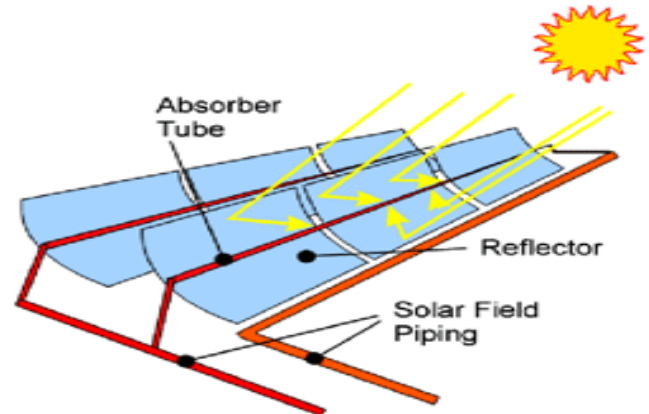

Fig.5.Parabolic trough collector

A parabolic trough is made of a number of solar collector modules (SCM) fixed together to move as one solar collector assembly (SCA). A SCM could have a length up to 15 metres (49 ft) or more. About a dozen or more of SCM make each SCA up to 200 metres (660 ft) length. Each SCA is an independently tracking parabolic trough. The mirror is oriented so that sunlight which it reflects is concentrated on the tube, which contains a fluid which is heated to a high temperature by the energy of the sunlight. The hot fluid can be used for many purposes. Often, it is piped to a heat engine, which uses the heat energy to drive machinery or to generate electricity. The trough is usually aligned on a north-south axis, and rotated to track the sun as it moves across the sky each day.

5. System Configuration

Solar thermal collectors can be arranged in series or in parallel. Solar collector fields with same amount of collectors disposed in a number of series connected panels, which can be then arranged in parallel (Fig. 2.3a) or cascade (Fig. 2.3b). Fluid flow rate, along the solar thermal system, does not change when panels are connected in series, while fluid temperature increases from previous panel to next panel. Instead, fluid flow rate changes along the solar thermal system when panels are connected in parallel and fluid temperature is the same at the end of each branch. Therefore, in the configuration shown in Fig.

2.3a, fluid temperature is the same at the end of each branch of panels connected in series, while system flow rate increases from branch to branch. For the same flow rate and number of collectors, pressure drop, which the circulation pump has to exceed, decreases with the number of branches in parallel and increases with the number of collectors in series (Picón-Núñez et al. 2014). Ideally, panels should be connected all in parallel to minimize the pressure drop. However, ensuring same flow rate distribution among each panel complicates the system control and design; the investment may not compensate the benefits. Thus, solar thermal collectors are arranged in series when the design system flow rate is low, while when the design flow rate is high collectors are arranged in parallel branches of series collectors.

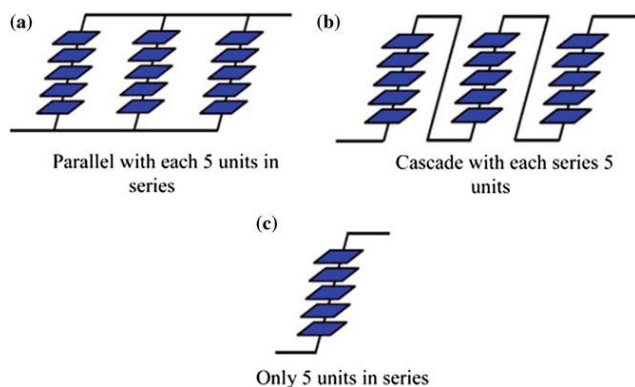

Fig.6. Arrangement of solar units

Solar thermal systems are often equipped with storage tank in order to store energy produced in a certain moment of the day and not utilized. Collectors can be connected only to the tank or to both tank and indoor heating distribution system as shown in Fig. 2.4. The last configuration, which is capable to increase the solar thermal energy yield compared to a solar thermal buffer system with small storage tank, is recommended only if the indoor distribution system requires low temperature such as radiant floor systems (Glembin et al. 2016).

Usually solar collectors are filled with brine; a mixture of water and glycol. Indeed, solar collectors loop is generally connected to the rest of the system through a heat exchanger. Nowadays, for residential applications solar collectors with drain back systems, syphon effect based, are becoming popular. These systems are able to increase the efficiency and the design of the system, reducing the necessary components, such as expansion

vessel, air vents and heat exchanger (Botpaev et al.2014). In such system the heat carrier is water, which makes them more eco-friendly than conventional solar thermal systems.

6. Conclusion

The review shows that solar energy can be the best solution in terms of energy generation. A variety of solar collectors have been reviewed, including non-concentrating types and concentrating types. Among non-concentrating collectors, the evacuated type solar collectors show the best overall performance. Two different types of concentrating solar collectors have been described and compared: heliostat field collectors and parabolic trough collectors.

7. Reference

1. F. De Winter *Solar collectors, energy storage, and materials* The MIT press, Massachusetts (1991)
2. Kalogirou SA (2004) *Solar thermal collectors and applications*. *Prog Energy Combust Sci* 30:231–295. doi:10.1016/j.pecs.2004.02.001
3. Kalogirou SA (2009) *Performance of solar collectors*. *Sol Energy Eng* 219–250. doi:10.1016/B978-0-12-374501-9.00004-2
4. Kalogirou SA (2014) *Solar energy collectors*. *Sol Energy Eng* 125–220. doi:10.1016/B978-0-12-397270-5.00003-0
5. Niu X-D, Yamaguchi H, Iwamoto Y, Zhang X-R (2013) *Optimal arrangement of the solar collectors of a supercritical CO₂-based solar Rankine cycle system*. *Appl Therm Eng* 50: 505–510. doi:10.1016/j.applthermaleng.2012.08.004.
6. Sabiha MA, Saidur R, Mekhilef S, Mahian O (2015) *Progress and latest developments of evacuated tube solar collectors*. *Renew Sustain Energy Rev* 51:1038–154. doi:10.1016/j.rser.2015.07.016
7. *The Earth's energy budget*, <http://www.nasa.gov/images/content/57911main_Earth_Energy_Budget.jpg>; 2012 [accessed 16.11.1].
8. Picón-Núñez M, Martínez-Rodríguez G, Fuentes-Silva AL(2014) *Design of solar collector networks for industrial applications*. *Appl Therm Eng* 70:1238–1245. doi:10.1016/j.applthermaleng.2014.05.005

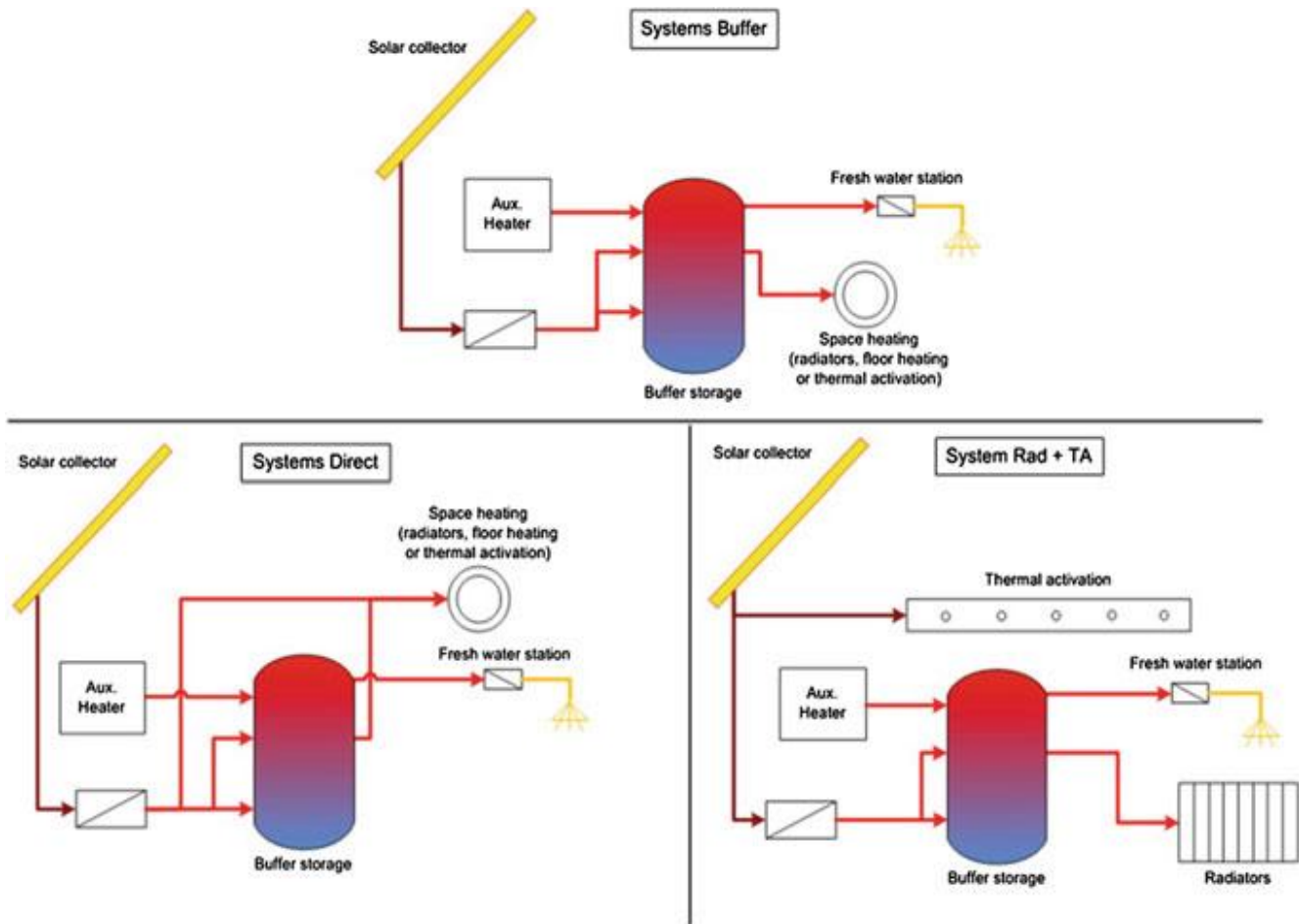

Fig.7-Solar thermal system configuration: direct or buffer