

# Design and Analysis of Savonius Vertical Axis Wind Turbine

Deepak Kr.Sharma<sup>1</sup>, Anmol<sup>2</sup>, Deepak Kumar<sup>3</sup>, Dheeraj Rai<sup>4</sup>, Rishab Ravi<sup>5</sup>, Nitish Yadav<sup>6</sup>  
Prof. Jayshri M. Lanjewar<sup>7</sup>

<sup>1-6</sup> Students of Mechanical Engineering Department, Priyadarshini College of Engineering, Nagpur.

<sup>7</sup> Faculty of Mechanical Engineering Department, Priyadarshini College of Engineering, Nagpur.

**Abstract-** In recent era, research and development activities in the field of renewable energy, especially wind and solar, have been considerably increased, due to the worldwide energy crisis and high global emission. The horizontal axis wind turbine cannot be used for household purpose. So, Savonius vertical axis wind turbine can be better option as it operate in low wind condition also. The choice for this model is to showcase its efficiency in varying wind conditions as compared to the traditional horizontal axis wind turbine and contribute to its steady growing popularity for the purpose of mass utilization in the near future as a reliable source of power generation..

**Key Words:-Renewableenergy, VAWT, Savonius, Multi stage generator, Household, Handmade PM generator**

## I- INTRODUCTION

The Savonius rotor is widely considered to be a drag-driven device. This indicates that the wind drag, acting on its blades, is the only driving force. However, it has been observed that at low angles of attack the lift force also contributes to the overall torque generation. Thus, it can be concluded that the Savonius rotor is not a solely drag-driven machine but a combination of a drag-driven and lift-driven device. Therefore, it can go beyond the limit of  $C_p$  established for the purely drag-driven machines (0.08). The idea of this turbine was proposed by

Sigurd Johannes Savonius in 1922 .but for many years it was not widely applied. However, recently its popularity has steadily grown. This results from the increasing

significance of urbanized areas, which have specific demands. The Savonius rotor seems to satisfy these particular expectations.

### 1.1 Advantages

- 1) Independence on wind direction, no additional control mechanisms are required
- 2) Ability to operate in a wide range of wind conditions (turbulence level, wind speed)
- 3) Electrical equipment can be placed at ground level
- 4) Low noise emission
- 5) High starting torque
- 6) Compact size
- 7) Simple and cheap construction.

All the above features make Savonius wind turbines suitable for the needs of residential use. However, Savonius turbines are not free from drawbacks such as relatively low efficiency and rotational velocity. Therefore, nowadays much effort is directed towards constantly seeking better designs that assure rotor performance improvement. Some of them also use CFD methods for this purpose.

### 1.2 Household Electricity Consumption

The electricity consumption was monitored in an house over the course of five months, and was then averaged out for a one month period. The calculations are shown below:  
Average Monthly Electricity Consumption = 328.69 kWh/month

Average Yearly Energy Consumption =  $328.69 \times 12 = 3944.28$  kWh/year or  $[3944.28 / (24 \times 365)] \times 1000 = 450.26$  W

For 10% of the electricity produced by the wind resource =  $0.1 \times 450.26 = 45.03$  Watts. Therefore a 45.03 Watt machine is required. But, Considering 5% losses the final

design is based on 50 watts. As we are using the multi stage generator we can predict that the power generation will be double i.e. 100 watts. So, with the design size of 50 watt turbine, the machine can give 100 watts output power.

**II-DESIGN**

**2.1 Savonius Rotor Design**

The key feature of this rotor is its simpler design. A Finish engineer Savonius introduced the Savonius rotor in 1920s. He has reformed the design of Flettener's rotor by dividing a cylinder into half, along its central axis and relocating the two semi-cylindrical surfaces sideways. This shape is akin to "S" when viewed from top as shown in Fig. 1. These type of rotors may be of two, three or higher bladed systems and can be used in single- or multi-staged arrangements. The working principle is based on the difference of the drag force between the convex and the concave parts of the rotor blades when they rotate around a vertical shaft. This is chosen because of its simple construction and self-starting capacity at low wind speed also.

$$P = C_p \frac{1}{2} \rho A V^3 \tag{1}$$

Standard wind equation (derived from power coefficient analysis)

V = 10 m/s (assuming this is the wind speed);

$\rho$  = 1.225 kg/m<sup>3</sup> density of air at sea level and 15°C;

C<sub>p</sub> = 0.245 (24.5% from the standard Power

Coefficient/Tip Speed Ratio diagram);

Power (P) = 50 Watts.

The equation below is used to calculate h:

$$\text{Area (A)} = \text{height (h)} \times \text{diameter (D)} \tag{2}$$

**Table- 1:**Height of rotor according to Diameter

Diameter	N(rpm)	A = 0.333 metre square, 50 Watts (5%) h (metres)
D = 0.4 m	477.5	0.83
D = 0.5 m	382	0.67
D = 0.6 m	318.3	0.56
D = 0.7 m	272.2	0.48
D = 0.8 m	238.8	0.42
D = 0.9 m	212.2	0.37
D = 1.0 m	191	0.333
D = 1.1 m	173.6	0.303

The size of 0.83x0.4 (dxh) is chosen considering the height benefit and maximum number of rpm.

**2.2 Generator Design**

Instead of using readymade alternator we decided to use permanent magnet handmade generator according to design requirement. This PM generator is of multi stage. This is for increasing the output with same size rotor. The number of coils and magnet used in this are 12 and 24 in each stage respectively. The 3 phase connection is drawn from the coils and the this output can store in heavy duty battery. This type generator is generally designed when there is special requirement of power. Following figure shows the typical 3 phase connection of coils for PM magnet generator.

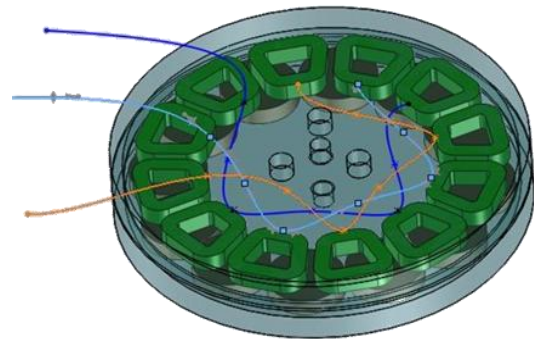

**Fig -1:** 3 phase connection of 12 coils

**2.3 Component and Material**

Rigid base – Mild steel

Inner fixed shaft- Mild steel (id=40mm, OD=50mm)

Outer rotary hollow shaft- Mild steel (id=80, OD=86)

Middle rotating disk- Mild steel

2 Ball Bearing- Bearing no. 6010(bore=50 mm)

Rotor blade- Aluminum alloy (No.of blade=4)

Magnets- Permanent earth magnet

Coils- Copper, Trapezoidal shape 50 turns

Battery- Lead acid heavy duty battery

**CAD Model**

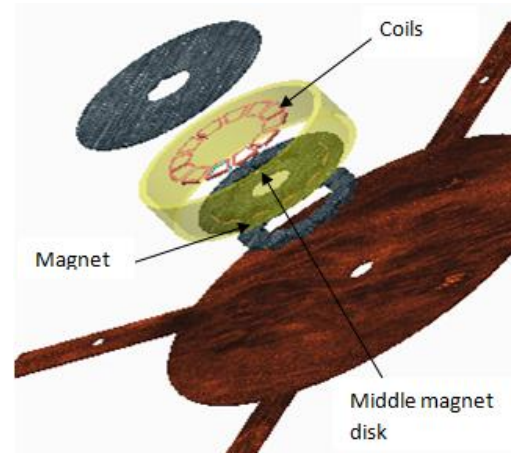

**Fig-2:** Expanded view of multi stage generator

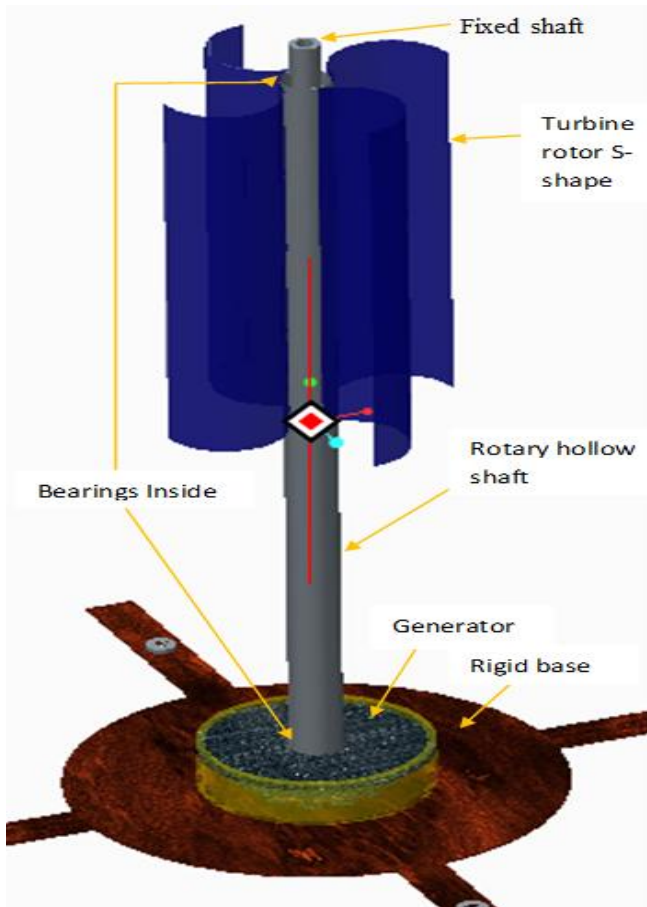

Fig-3: Savonius Vertical axis wind turbine

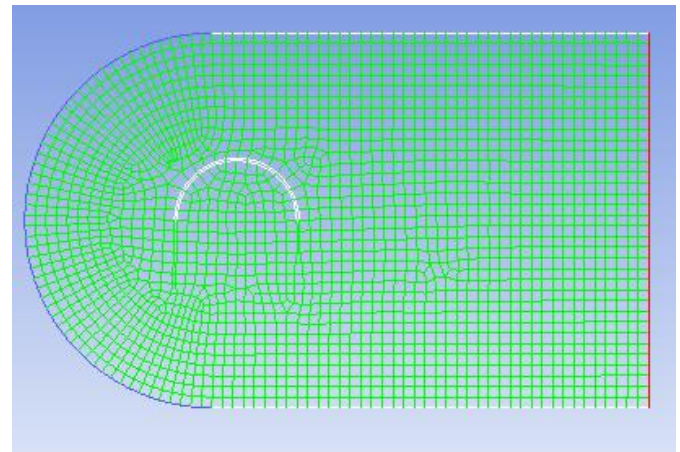
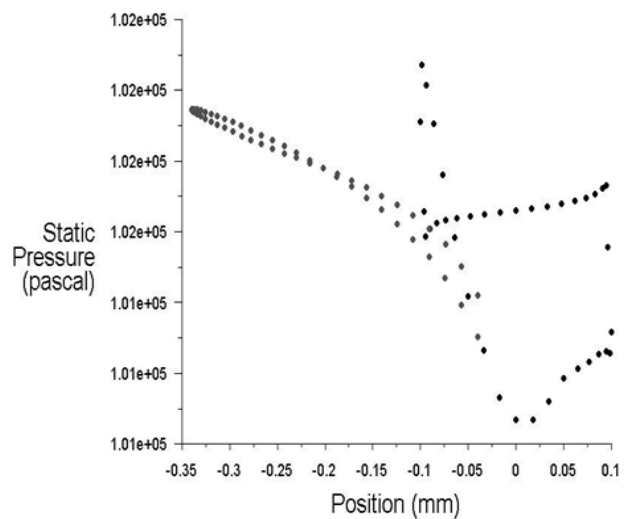

Fig-4: Aero foil shape

Following graph shows the pressure distribution along the blade due to inlet velocity:



Graph-1: Pressure vs. position of blade

Force calculation,

$$F = \sqrt{F_L^2 + F_D^2}$$

$$\text{Lift force} = F_L = \frac{1}{2} \rho V^3 A C_L$$

$$\text{Drag force} = F_D = \frac{1}{2} \rho V^3 A C_D$$

$$C_L = 0.385, C_D = 1.500$$

$$\text{Hence, } F = 31.585 \text{ N}$$

The values of co-efficient of lift ( $C_L$ ) and drag ( $C_D$ ) are got from following graph:

### III- ANALYSIS

#### 3.1 CFD

Computational fluid dynamics (CFD) is a useful design tool for wind power analysis. A large number of simulations can be performed, analyzed and optimized without investing in physical construction of many turbines with different geometrical configurations. Using CFD simulations, the torque and pressure on the rotor can be predicted. These can then be used to predict the turbine's power coefficient. Whenever the static analysis is to be done, the force exert on blade need to be calculate. So, Savonius rotor is the drag device but a little lift force also obtain in it. Hence, we have calculated the lift and drag force with the help of cfd analysis by using the blade cross section area as aero foil. Firstly defined the boundary condition then used inlet velocity input (10 m/s).

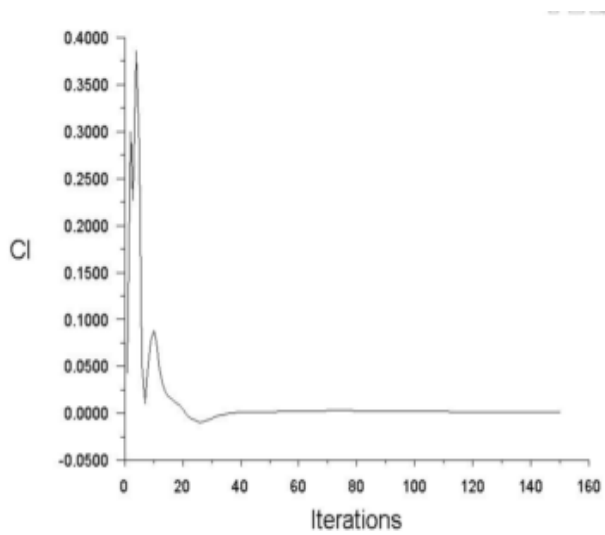

Graph-2: Co-efficient of lift vs. No. of Iterations

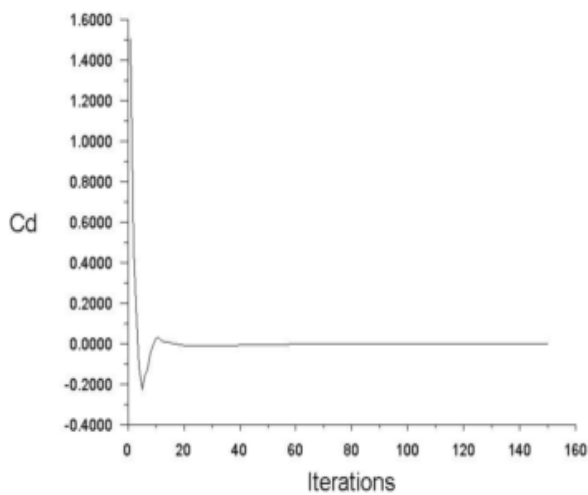

Graph-3: Co-efficient of drag vs. No. of Iterations

**3.2 Static structural**

Static Structural analysis of blade is generally done to check whether it is sustainable or not in the defined working environment. On the basis of calculated force, the analysis of blade is done by using aluminum alloy as the blade material. The following figure shows the analysis report:

Material= Aluminum alloy

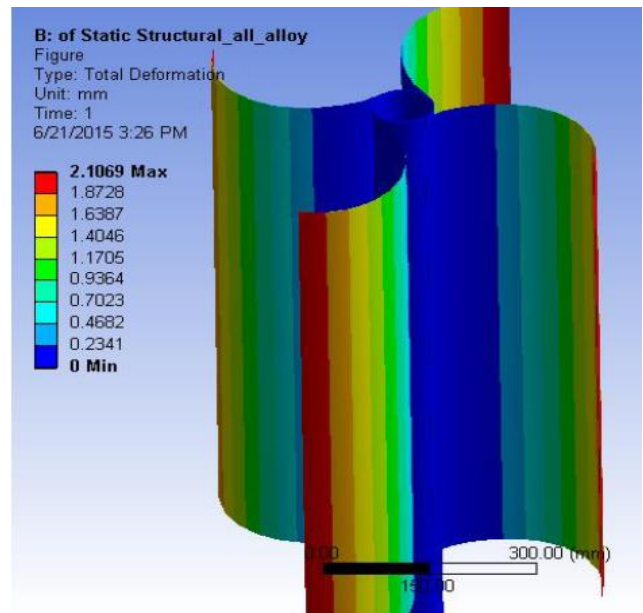

Fig-5: Deformation in Savonius turbine blades

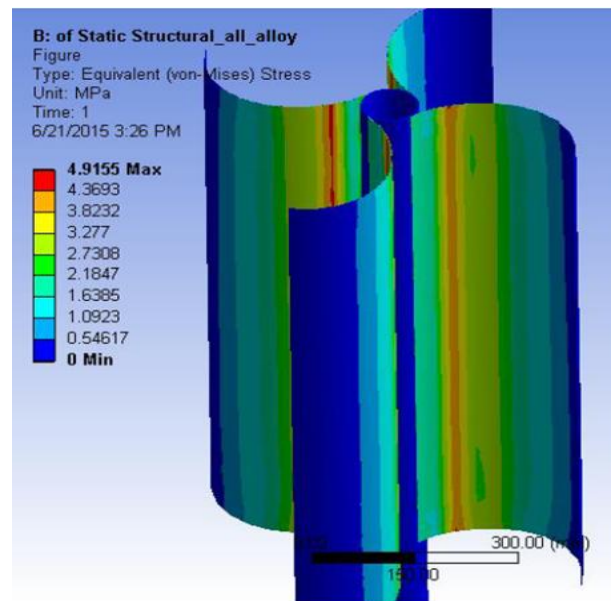

Fig-6: Equivalent Stress in Savonius turbine blades

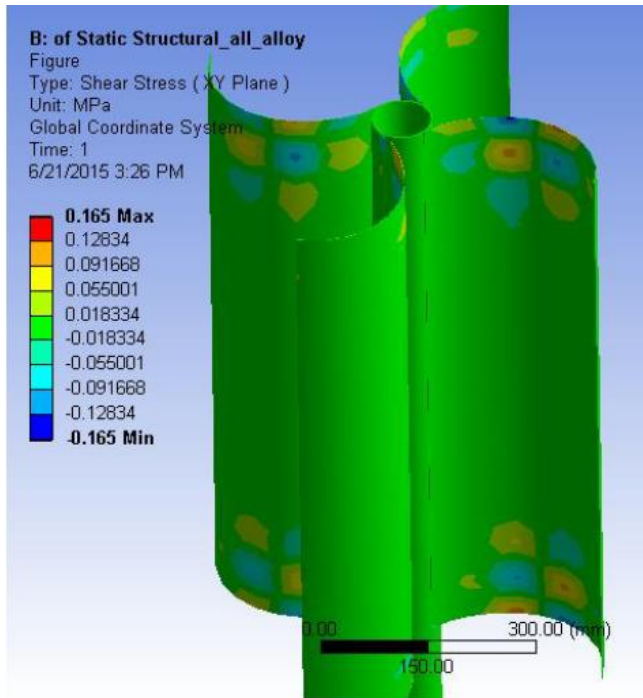

Fig-7: Shear stress on XY plane in Savonius blades

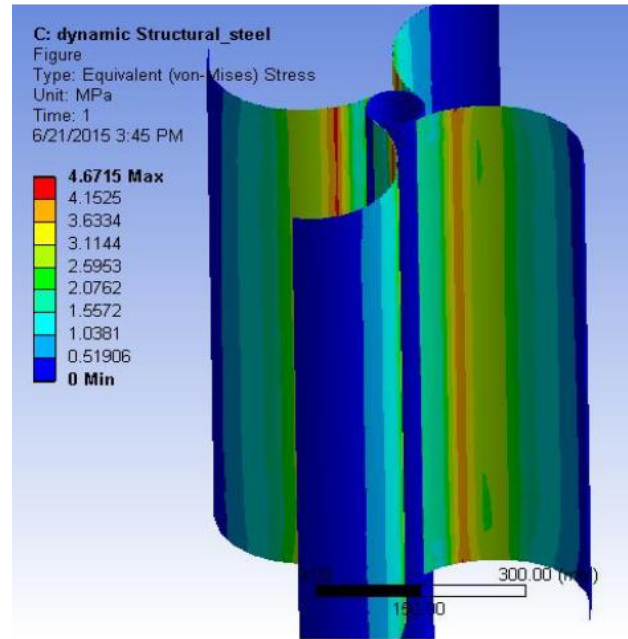

Fig-9: Equivalent stress in blades

### 3.3 Dynamic

Dynamic analysis is done to check the designed model under variable condition of load. In this case varying condition refers to the change in velocity of air with respect to time.

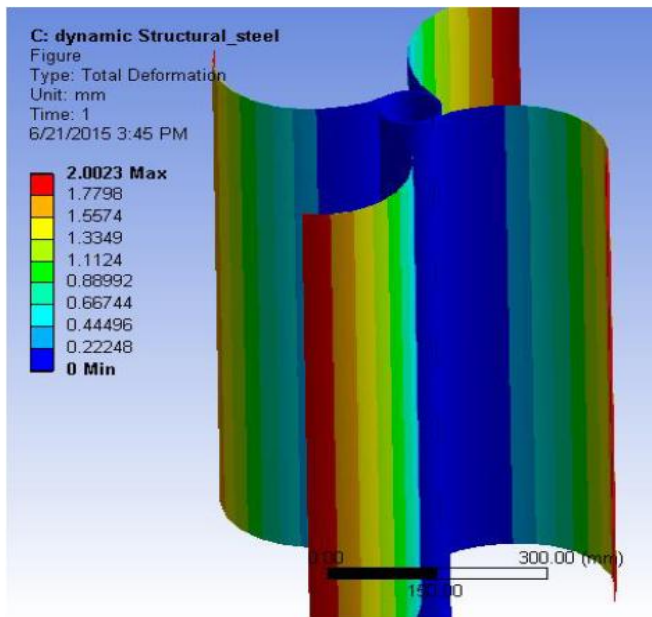

Fig-8: Total Deformation in blades

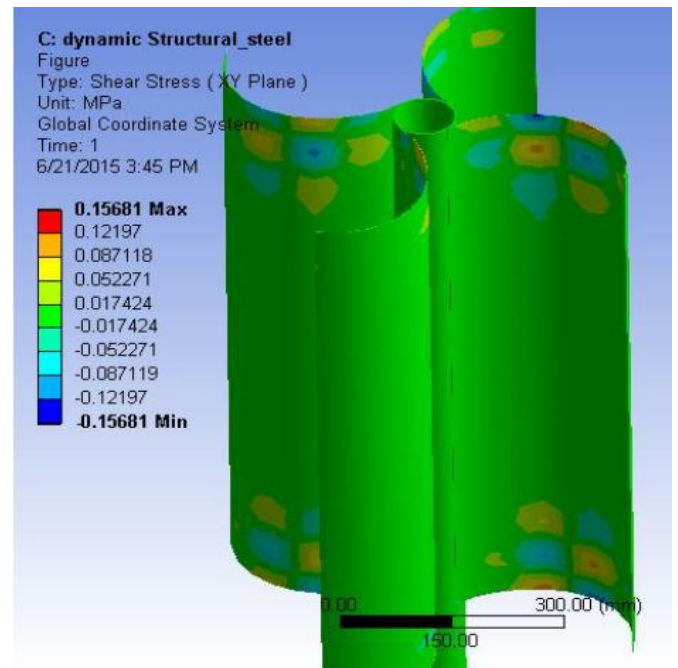

Fig-10: Shear stress on XY plane in blades

### IV- SOFTWARE TOOL

Today's world is deal with technology in every field. There are certain software in market which is used for design and analysis of the product to determine its

behavior under defined conditions. It is better to use these software before directly go for manufacturing. It helps to gives errorless design and save the time and money also.

#### 4.1 Design

Design of model is done in creo software. This is more accurate for 3D modeling.

#### 4.2 Analysis

It is done in Ansys software. Various types of analysis such as cfd,static,dynamic can be done in this software.

### V- METHEDOLOGY

**Table-2:** Applied Procedure for Savonius VAWT

[1] Average Monthly consumption of electricity in an house
[2] Percentage of electricity to be contribute to the houseby VAWT
[3] Size of the turbine required for that power generation
[4] Designing of the turbine rotor on the basis of calculation.
[5] Design of the multi stage hand made permanent magnet generator
[6] Consideration of other part such as bearing, shaft, base, disk, magnet and coils etc. on the basis of rotor size
[7] CAD model of the Vertical axis wind turbine.
[8] Analysis of the designed model
[9] Fabrication of the VAWT
[10] Testing it in different wind condition.
[11] Results

### VI- RESULTS AND DISCUSSION

The vertical axis wind turbine is a small power generating unit with the help of free source of wind energy. It is designed under consideration of household use. The analysis results of the wind turbine governs that the design is under safe limit. It is check in analysis for worst condition working by using velocity 10 m/s.

#### 6.1 Analysis Results

Blade Material= Aluminum alloy

##### 1. Computational fluid dynamics (CFD)

$$C_L=0.3850, C_D=1.5000$$

$$F_L=7.852 \text{ N}, F_D=30.594 \text{ N}$$

$$F = 31.585 \text{ N}$$

##### 2. Static Structural

Total Deformation- Max= 2.1069 mm

Min = 0 mm

Equivalent stress - Max = 4.915 Mpa

Min = 0 mm

Shear stress - Max = 0.165 Mpa

Min = -0.165 Mpa

UTS = 310 Mpa

#### 3. Dynamic

Total Deformation- Max= 2.002 mm

Min = 0 mm

Equivalent stress - Max =4.671 Mpa

Min= 0 Mpa

Shear stress - Max=0.1568 Mpa

Min= -0.1568 Mpa

From the above obtained value of the analysis report, it can be conclude that the design is safe and within the permissible limit. The field testing of the turbine will be carried out to get the power output result.







### 7. CONCLUSION

There are number of sources for generation of power but in the recent years wind energy shown its potential as the clean source of energy and contributing to the high energy demands of the world. Vertical axis wind turbine is the best option for the area which are under load sheading. The output from the turbine is use to charge a heavy duty battery. This can be beneficial than inverter back up. Following are the some conclusions drawn from this project:

- [1] At least 10% power of the consumption can be fulfil by this set up.
- [2] Multi stage generator is the double generation concept with the same size rotor.
- [3] Gear arrangement can increase the number of rpm in case of low wind speed.
- [4] This turbine is generally suitable for 8 to 10m of height above ground level. Because at ground level velocity of air is very less.
- [5] Combination of alternator with gear arrangement can be used to increase output but unnecessarily it will increase the cost of machine.
- [6] Considering the all-weather point of view the material use should be non-corrosive.
- [7] The alternate option for turbine blade material is reinforced glass fibre because of its more elastic nature but it is costlier than aluminium alloy.
- [8] The cost of the machine should be as minimum as possible. So that it will be economical for everyone to purchase.

### REFERANCES

- [1] M.C.Percival, P.S.Leung, P.K.Dutta, University of Northumbria, School of Engineering, UK. Development of vertical turbine for domestic electricity generation.
- [2] Antonio Gagliano, Francesco Nocera. International journal of Energy and Environmental Engineering (IJEEE) 2013. Assessment of micro-wind turbines performance in the urban environments: an aided methodology through geographical information system.
- [3] 3. Sukanta Roy, Ujjwal K. Saha IIT, Guwahati. Review on numerical investigations into the design and development of savonius wind rotors. *Sciencedirect (Renewable and sustainable energy reviews* 24 (2013)73-83)
- [4] Joushua Yen, Noor Ahmed. University of new south wales (NSW) sydney, Australia. *Sciencedirect (Procedia engineering* 49 (2012) 99-106). Improving safety and performance of small-scale vertical axis wind turbines.
- [5] Murat Islam. A MS candidate, School of Aerospace, Mechanical and civil Engineering, University of Manchester, England. Design and development of micro wind turbine.
- [6] G.D.Rai, *Renewable energy sources, book.*
- [7] Blackwell BB, Sheldahl R, Feltz LV. *Wind Tunnel Performance Data for Two and Three Bucket Savonius Rotor. Journal of Energy* 1978; 2:160-164.
- [8] Le Gourieres D. *Wind Power Plants Theory and Design; Pergamon Press Ltd, 1982.*
- [9] Murat islam, design and development of VAWT, a report
- [10] Manwell JF, McGowan JG, Rogers AL. *Wind energy explained: theory, design and application; John Wiley and Sons Ltd: Chichester, 2002.*
- [11] Moutsoglou A, Weng Y. *Performance tests of a Benesh wind turbine rotor and a Savonius rotor. Journal of Wind Engineering* 1995; 19: 349-362
- [12] Kroms, *Wind Power Stations Working in Connection with Existing Power Systems. 1954, A.S.E.Bull. p. 135-144.*
- [13] Hütter, U., *The Development of The Wind Power Installations for Electrical Power Generation in Germany. 1973, NASA Technical Translation: Washington DC.*
- [14] *Small-scale wind energy, in Policy insights and practical guidance (CTC738), F.a.R.A. Department for Environment, Editor. 2008, Carbon Trust and Met Office.*
- [15] Martin Best, A.B., Pete Clark, Dan Hollis, Doug Middleton, Gabriel Rooney, Dave Thomson and Clive Wilson, *Small-scale Wind Energy – Technical Report, in Urban Wind Energy Research Project Part 1 – A Review of Existing Knowledge. 2008.*
- [16] Hau, E., *Wind Turbines. 2nd ed. Fundamentals, Technologies, Application, Economics. 2006, Berlin: Springer.*
- [17] Bruce E. Boatner, E.R.D., Eagle, ID (US) 83616, *Vertical Axis Wind Turbine With Articulating Rotor. 2010: United States. p. 32.*

Photo	Details
	<b>Name: Deepak K Sharma</b> Branch: Mechanical College: Priyadarshini College of Engineering Nagpur.
	<b>Name: Anmol</b> Branch: Mechanical College: Priyadarshini College of Engineering Nagpur.
	<b>Name: Deepak Kumar</b> Branch: Mechanical College: Priyadarshini College of Engineering Nagpur.
	<b>Name: Rishab Ravi</b> Branch: Mechanical College: Priyadarshini College of Engineering Nagpur.
	<b>Name: Dheeraj Rai</b> Branch: Mechanical College: Priyadarshini College of Engineering Nagpur.
	<b>Name: Nitesh Yadav</b> Branch: Mechanical College: Priyadarshini College of Engineering Nagpur.
	<b>Faculty Name: Jayshri M. Lanjewar</b> Department: Mechanical College: Priyadarshini College of Engineering Nagpur.