

Remote Control Induction Motor Using Three Phase

Miss. Payal Namdeo Tembhurne¹, Miss. Ankita Khandait², Prof. D. R. Tutakne³

¹P. G. Student, ²Assistant Professor ³Professor
Electrical Department, Wainganga College of Engineering & Management, Nagpur- 441108

payaltembhurne@gmail.com

Received on: 10 April, 2022

Revised on: 16 May, 2022,

Published on: 18 May, 2022

Abstract: The project uses wireless technology to drive an induction motor in both forward and reverse directions for the desired purpose. An exhaust fan, for example, can be utilised in both directions to bring fresh air in and exhaust hot air. This can be used with a traditional exhaust fan that only moves in one direction. This method demonstrates how to rotate a squirrel cage induction motor both clockwise and counterclockwise. It also has the ability to use wireless technology to control the motor's direction. Multiple access mechanism is used in the suggested system. The Keil vision 4.0 programme is used to validate the proposed system simulation. Power supply, controller, relay, and AC motor are all included. The suggested system is mimicked by entering commands into a virtual terminal and validating the three modes of operation with the controller's output. The load is rotated in the "FORWARD" and "REVERSE" directions by the controller.

Keyword- Microcontroller, Relay, Induction Motor, and so on.

I- INTRODUCTION

AC machines are currently preferred over DC machines in the majority of applications due to their simple and durable design without mechanical commutators. Induction motors are the most commonly used motors in appliances such as industrial control and automation, and they are often referred to as the motion industry's workhorse. Three-phase induction motors are at the top of the heap in terms of machine efficiency,

robustness, dependability, durability, power factor, ripples, consistent output voltage, and torque. Motor control is an important part of embedded applications that is frequently overlooked. Residential washing machines, fans, and hand-held power tools, as well as car window raise, traction control systems, and other industrial drives, are all examples of motor control applications. In almost all applications, there is a significant shift away from analogue motor control to precision digital motor control employing various processors. Induction motors with digital control operate more efficiently, resulting in longer motor life and lower power consumption. Although there are several induction motor control strategies in use today, the most common is to generate a variable frequency supply with a constant voltage to frequency ratio. Wireless communications has existed since the dawn of time, when humans first learnt to communicate. Humans used to communicate important events like enemy invasions or royal births by sounding horns or lighting fires in the early days of civilisation.. While simple messages could be sent this way, communicating across large distances required a lot of work because watchtowers had to be placed in close proximity to each other and constantly manned, and the amount of messages was tiny. Induction motors are widely employed in industrial applications and control. The single phase induction motor with a permanent split capacitor is the most basic and extensively used of this type. This classification can be utilised in the case of traditional exhaust fans that only

rotate in one direction. This proposed method demonstrates how to rotate a squirrel cage induction motor both clockwise and counterclockwise. It also has a remote control for controlling the motor's direction.

When we require operation of induction motor in both direction as well as speed variation then this system (remote control device using bidirectional rotation and also speed variation) is easily installed. Example: Electric train system, rolling mills.

II -LITERATUREREVIEW

The project is designed to drive an induction motor for the required application in forward and reverse directions using wireless technology. For an example, an exhaust fan can be used in both the directions to fresh air in and throw hot air out. This can be used in case of conventional exhaust a fan that rotates in one direction only. This method demonstrates how to rotate a squirrel cage induction motor both clockwise and counterclockwise. It also offers the ability to control the motor's direction with a TV remote. When a TV remote button is pressed, an IR signal in RC5 code is sent, which is received by the TSOP-1738 IR receiver. The TSOP output is routed to an 8051 microcontroller, which is connected to a relay driver IC. After then, for a split-phase induction motor to rotate in both directions, the relay switching is done in by- stable mode. It can be improved further in the future by employing thyristors instead of relays to regulate the operation of induction motors for noise-free operation.

Now days all home appliances are preferred to control wired and wireless mechanism. In our project we are proposed to control the direction of induction motor high efficiency deliver from input to output supply.

III -TRANSMITTER

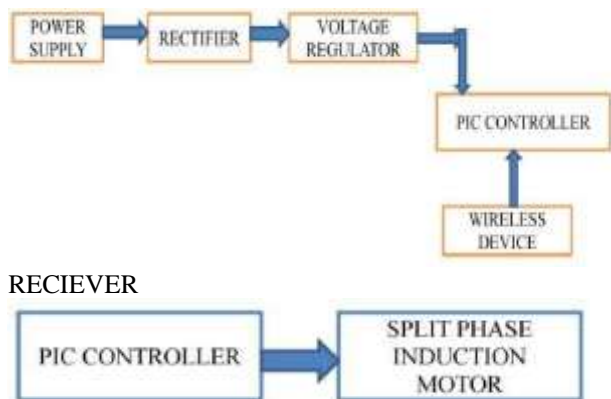

. Fig 1-Block diagram of proposed method

Figure 1 shows the diagram of transmitter and receiver for the proposed method. In this manner, a 230V power source is sent to the rectifier circuit, which converts the 5V DC to 5V DC and then to voltage regulation, which regulates the voltage for the controller. The GSM is connected to the controller. It is in charge of moving forward and backward.

IV- PLAN OF THE WORK



Material used in their project

- 8051 series Microcontroller
- Crystal
- IR Sensor
- Relay Driver IC
- Relay
- Transformer
- Diodes
- Voltage Regulator
- Capacitors
- LED
- Resistors
- TV Remote

Block diagram of remote control device of induction motor with bidirectional rotation

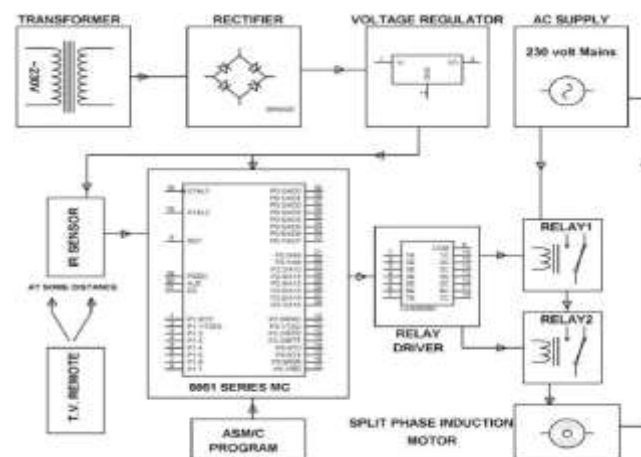

Circuit diagram

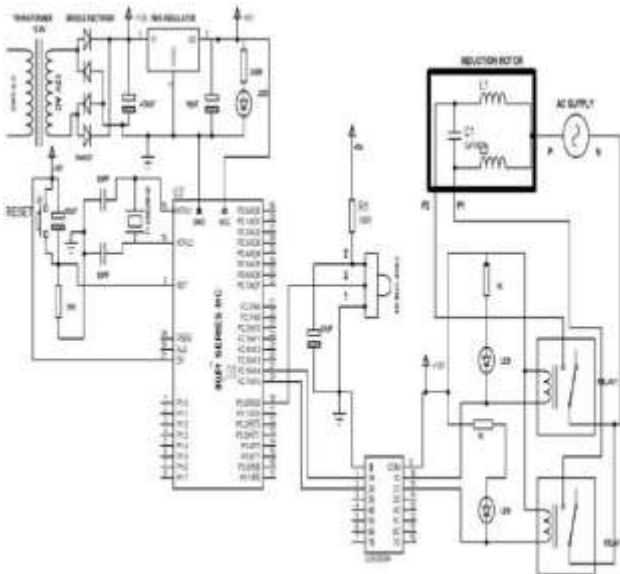

Power supply:-

Circuit diagram of power supply circuit

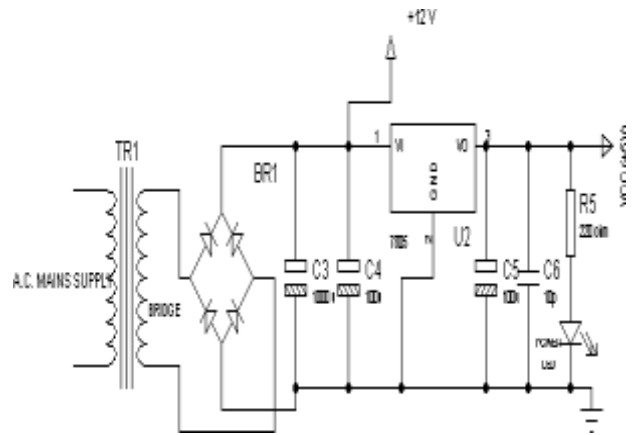
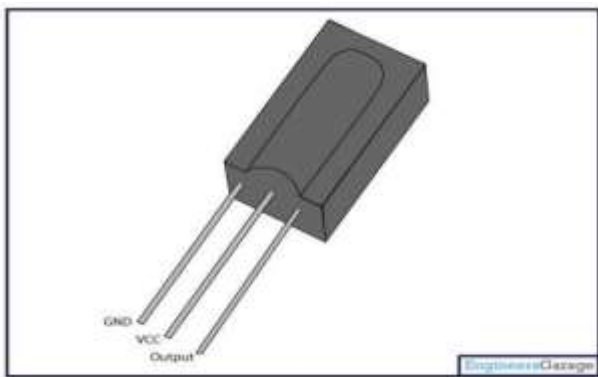

Fig 3 of circuit diagram of power supply circuit
 Component of power supply circuit

- 1) Power circuit consists following equipment.
- 2) Step-down transformer of 230/12V
- 3) Bridge rectifier
- 4) IC 7808
- 5) Filter capacitor (Electrolyte capacitor) Ceramic Capacitor

TSOP 1738 RX



The TSOP17.. – series are miniaturized receivers for infrared remote control systems. PIN diode and preamplifier are assembled on lead frame, the epoxy package is designed as IR filter. The demodulated output signal can directly be decoded by a microprocessor. TSOP17.. is the standard IR remote control receiver series, supporting all major transmission codes.

Features

- Photo detector and preamplifier in one package
- Internal filter for PCM frequency
- Improved shielding against electrical field disturbance
- TTL and CMOS compatibility
- Output active low
- Low power consumption
- High immunity against ambient light

The step-down transformer steps down the 230V AC supply to 12V. The 12v is now fed to the bridge rectifier, which converts the AC source to DC. During the positive half cycle of AC voltage, the bridge rectifier is made up of four diodes, two of which have forward bias and the other two have reverse bias. During the negative half cycle of the AC source, the reverse is true. The 12v DC is provided to the regulator IC LM7812 after rectification. The LM7812 positive voltage regulator keeps the load at a constant 12 volts DC. The motor is powered by a 12 volt DC supply. The filters capacitor filters the AC components present in the output since it may be pulsing DC.

Bridge Rectifier: - Rectification is an AC to DC conversion technique. The AC from the transformer is fed into the rectifier input, which converts it to DC. For power supply design, bridge rectifiers or diodes grouped in a bridge called Diode arrangement are utilised. To achieve full-wave rectification, a bridge rectifier employs four diodes in a bridge configuration. This is a common design, both with individual diodes wired as illustrated and with single component bridges with an internal diode bridge.

SIMULATION

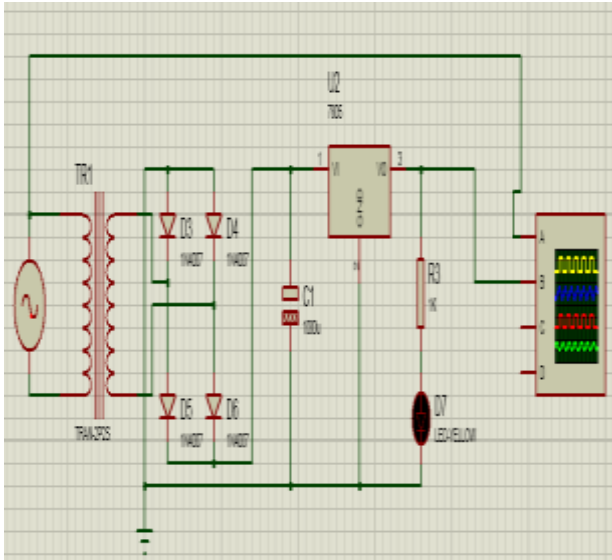

Fig 4- Circuit diagram for Power supply

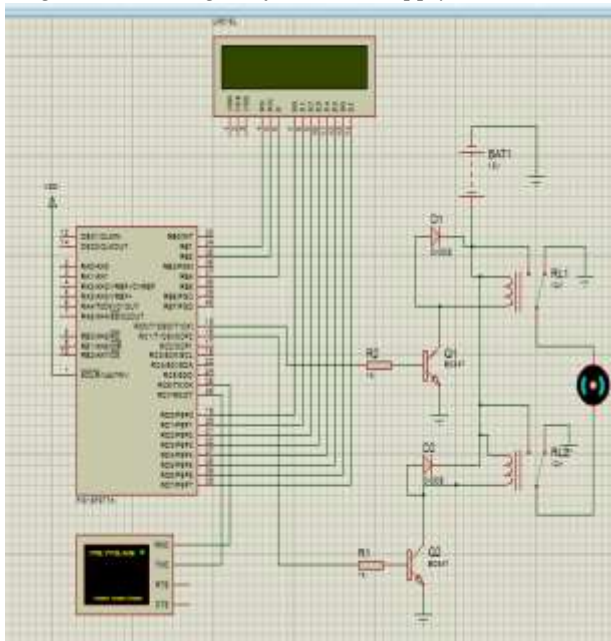

Fig 5- Simulation for Proposed method

The objective of the 5V power supply, as shown in Figure 4, is to give power to the microcontroller unit (MCU). A single step down transformer provides the power supply. The step down transformer steps down the 230V input supply in both of these power sources. A bridge rectifier is used to convert it to dc 5V in the next stage. The dc voltage at the output side is regulated using the 7806 regulator type.

In this proposed method, Figure 5 depicts the proposed procedure. The PIC (Peripheral Interface Controller) series microcontroller was utilised in this project. The 40-pin controller is related with the PIC16F877A chip. An opto-isolator is an electronic device that is also known as an opto-coupler, photo coupler, or optical isolator.

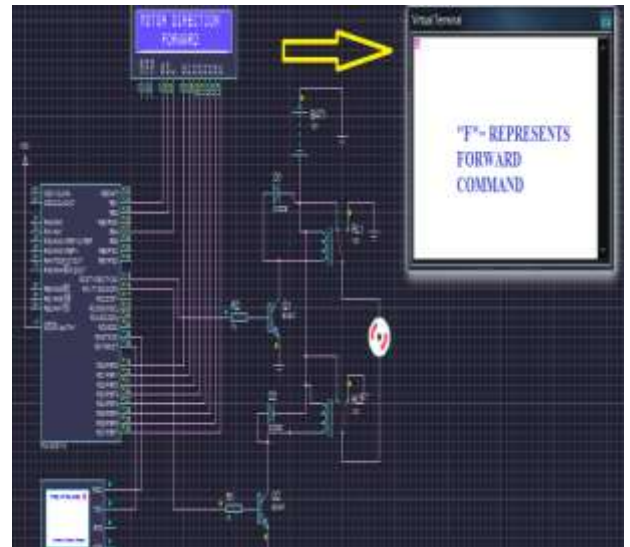

Fig 6.-Output for forward direction

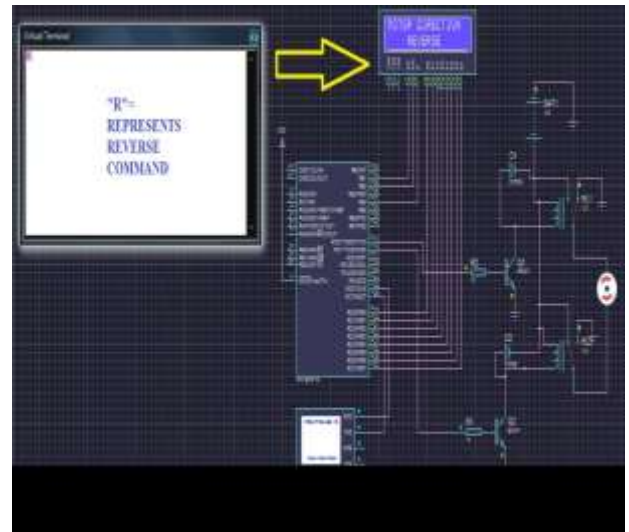

Fig 7.-Output for Reverse direction

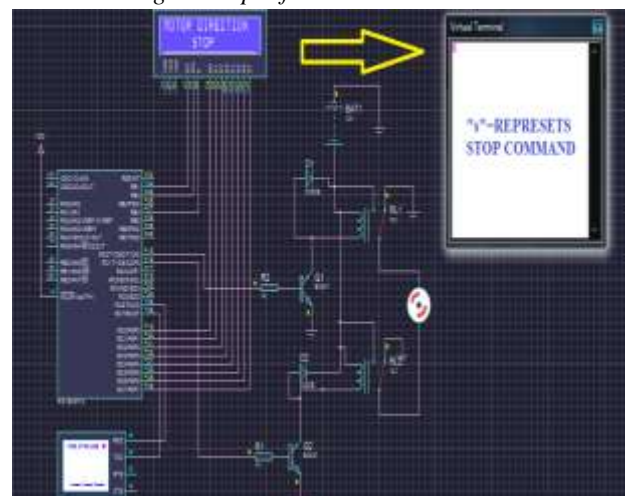

Fig 8-Output for Stop command

Figure 6, 7, 8 shows the diagram of output of the forward, reverse, and stop commands which typed in the virtual terminal and the induction motor rotation for

simultaneous response for virtual terminal input.

V- MATLAB SIMULATION FOR SINGLE PHASE INDUCTION MOTOR

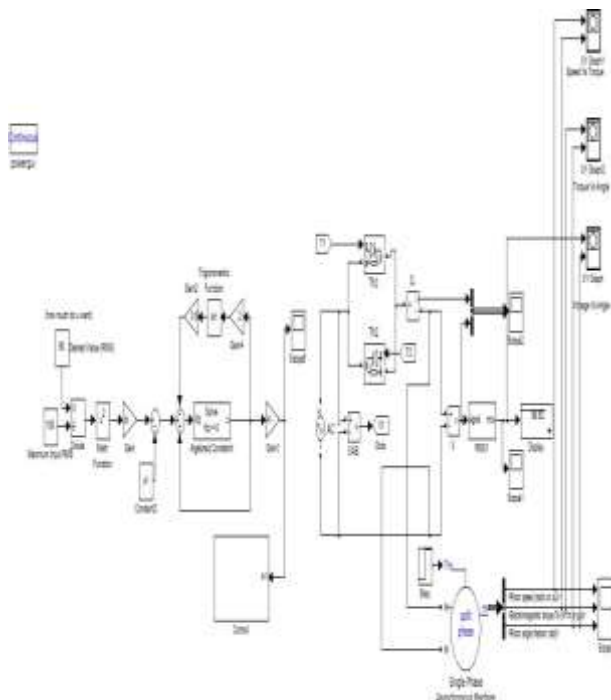

Fig.9 simulation model

Simulink modelling of thyristor controlled power for induction motor is shown in the figure. Hardware is different from Simulink in the thyristor control the power of induction model because hardware has a rectifier voltage regulator, opto isolators, and an 8051 micro controller to generate the pulse, but in Simulink we utilise a pulse generator to generate the pulse.

Result and Discussion

Result and discussion the modelled circuit was simulated and the results were obtained. The input waveform obtained from the alternating current (AC) signal 220v single phase power line is shown in the figure.

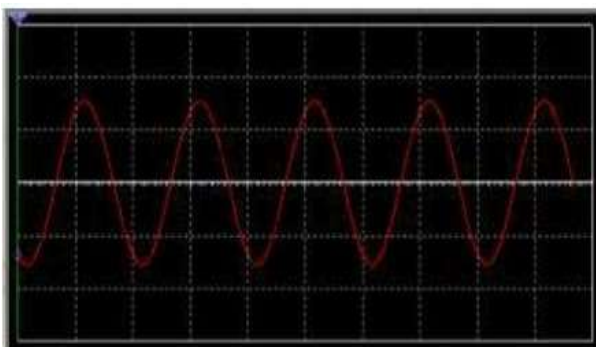

Fig.10- Input AC Signal Voltage 220V

The above signal is fed into the relaxation oscillation circuit to generate an "on" and "off" signal which turns the thyristor "on" and "off" at a present value of potentiometer.

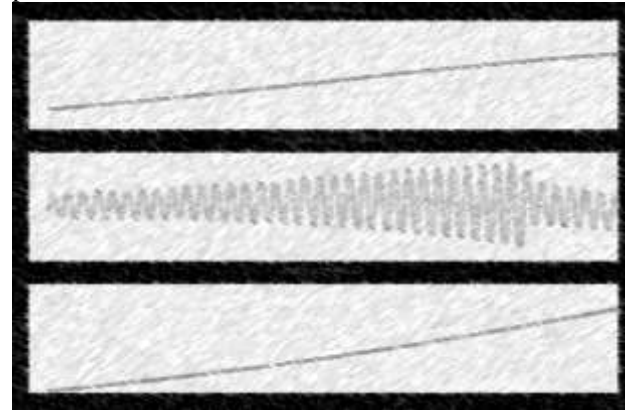

Fig.11-waveform of simulation

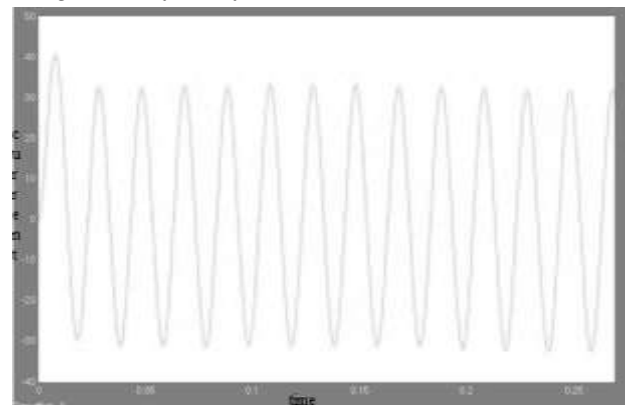

Fig.12 Current Vs Time

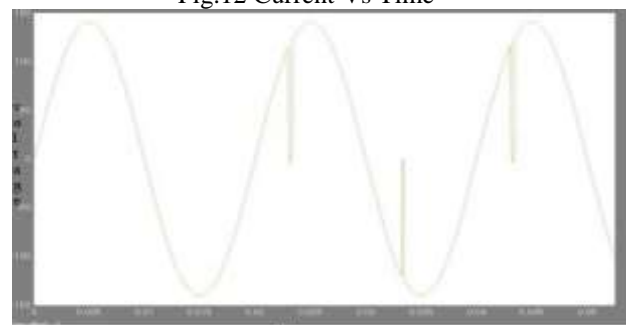

Fig.13 Output voltage Vs Time



Fig.14 RMS Voltage Vs Time

VI- CONCLUSION

This paper describes a modelling and simulation of single phase AC voltage regulation for a single phase induction motor. Multisim simulation results were found to be in good agreement with their MATLAB counterparts. Controlling the firing angle of an induction motor allows for speed control. Proteous software was used to implement bidirectional induction motor rotation. The suggested system is mimicked by entering commands into a virtual terminal and validating the three modes of operation with the controller's output. Depending on the input we give the virtual terminal, the controller causes the load to rotate "FORWARD" or "REVERSE." The induction motor stopped when the virtual terminal received the input "S." Wireless induction motor control in both directions

REFERENCES

- [1] Saidur ,R, Mekhilef,S Ali, .M. A. Safari .A . Mohammed .H.A—Applications of variable speed drive (VSD) in electrical motors energy savings, *Renewable and Sustainable Energy Reviews* ,vol. 16, no. 1, pp. 543-550, January 2012.
- [2] Ibrahim. M Alsofyani, N. R. Idris .N, —A review on sensor less techniques for sustainable reliability and efficient variable frequency drives of induction motors, *Renewable and Sustainable Energy Reviews*, vol. 24, pp. 111-121, August 2013.
- [3] Nabaee. A Kenichi. O Hiroshi. U. Kurosawa., R —An approach to flux control of induction motors

operated with variable-frequency power supply, IEEE Trans. Ind. Appl., vol. IA-16, no. 3, pp. 342-350, 1980.

- [4] Murata .T Tsuchiya. T Takeda .I —Vector control for induction machine on the application of optimal control theory, *IEEE Trans. Ind. Appl.*, vol. 37, no. 4, pp. 282-290, 1990.
- [5] Lorenz. R.D . Lipo T.A . Novotny. D.A—Motion control with induction motors, *Proceedings of the IEEE*, vol. 82, no. 8, 1215 1240, 1994.
- [6] Krishnan. R —Electric motor drives modelling, analysis and control, 1st ed., 2001 Prentice-Hall International, New Jersey.
- [7] Kovacs. P.K—Transient phenomena in electrical machines, Elsevier Science Publishers, Amsterdam
- [8] Krause .P.C Wasynczjk, .O —Analysis Of Electrical Machinery, IEEE Press, New York.
- [9] Stanley .H.C —An analysis of the induction motors, *AIEE Trans.*, vol. 57, pp. 751-755, 1938.