

An IOT Based Smart Password Protected Door Lock Security System

Raj Uday Vichare¹, Pratiksha Dayanand Jadhav², Umakant B. Gohatre³, Dnyanesh Balu Dhavade⁴

^{1,2,3} BE Student, ⁴Assistant Professor ,
Department Electronics and Telecommunication Engineering,
Smt. Indira Gandhi College of Engineering,
Ghansoli, Navi Mumbai, Maharashtra, India 400701

rajvichare2757@gmail.com

Received on: 29 March, 2023

Revised on: 17 April, 2023

Published on: 19 April, 2023

Abstract –Our society will always have a need for a low-cost electronic home security system that works in tandem with other security measures to make homes less vulnerable to intrusion. We're developing a system to provide automated door locks that need a password in order to alleviate this issue. We want to employ today's affordable technological tools to construct a comprehensive, individually tailored home security system. We're crossing our fingers that this effort will help deter bandits, thugs, and other bad guys from operating in the area. In everything that we do, our number one priority is always the protection of our loved ones. Every person has an inherent urge to feel protected. The ability to restrict entry at certain doors is a crucial aspect of our overall security system. The security of doors secured with traditional locks has been compromised to the point that they may be easily broken through by any determined intruder. Our goal is to establish a system that is useful around the clock. Password-protected door locks ensure that only authorized individuals may enter restricted areas. This method allows us to set a password to open the door, so increasing security and preventing illegal entry. This method gives the user options for changing or resetting the password in case they forget the original combination. A more secure and economical method of

locking and unlocking, this automated password-based system will bring convenience to the user without sacrificing safety.

Keywords— *Microcontroller (Arduino), Solenoid Lock, Keyboard, Display.*

INTRODUCTION

The password door locking system can be used in Homes, offices; desktop PC security is about protecting our life and property. Ensuring the safety of people and their valuables is very important to prevent illegal handling. Therefore it is very important to focus. Purity of The door lock or gate in order to avoid further problems in the .Monitored area. The system check the validity of the password entered by the user and unlock only for authorized user. This system proves to be the optimal solution of preventing unauthorized access. The door lock is a two-unit system where one unit monitoring. And the user enters and the other users exit. The number of password. Put in practice Depend .Under user. Each user will receive a unique four-to-five-digit password. To use the unlock the door .For different types Users having different password. This allows us to keep a record of the people who have used the door lock. This

log will be stored in the documents in the cloud. The document will contain the user names, enter time and exit. This Future help to ensure. Increase security of the door locking system. The door lock is also equipped with an anti-gesturing mechanism where this system locks after five Incorrect attempts. In order to use the door lock again .The system must be reset, even the use of mechanical locks. There is crime robberies because such locks are easily broken. So, there is we need to invert another kind of locks that cannot be easily broken. So, many authors introduce different kinds of digital door lock. Automatic password-based door locks.

METHOLOGY

Is to design and implement equipment for the input, process and output equipment’s. The input device is the keyboard which send all the input data to the next device which is Arduino. Arduino act as a processing device here inside the keyboard. Is the 4x4 matrix and there are 16 circuits. In the, press any key then any of the circuit will turn on. If we press the A key then circuits below the button is activated and sends the information to the Arduino. Before pressing button. The entire circuit is running off and row and a column from a combination circuit in the password wise Arduino automatic door lock system.

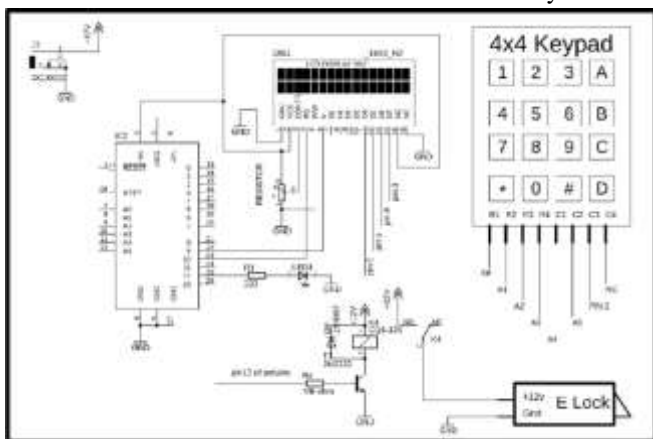

Figure 1: Circuit Diagram

when we press a key, press a key, the audio gets the notification that which circuit is currently activated and there is a character assigned to the circuit that can be displayed on the serial monitor. If you have some basic knowledge, you can easily watch the character on the serial murderer and sometimes. There may be error to get the correct character which you can easily solve.

This is basically a user defined password-based circuit breaker where you must create your own password. Now

you can enter the password first it will be asking queue the password to register and then enter 12345 in the password and now you can create your own password and procedure is listed here.

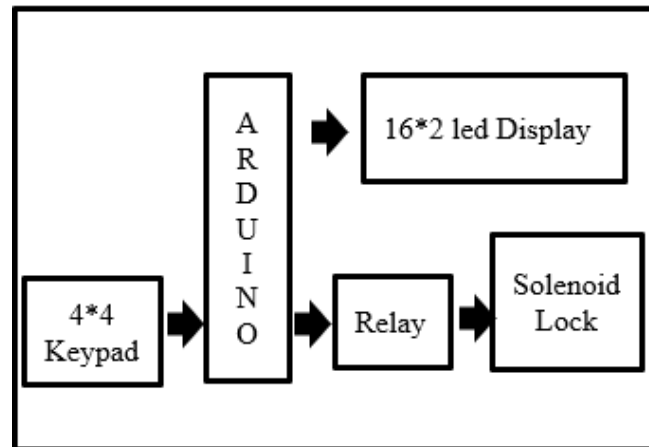

Figure 2: System block diagram

when we press the KEY, the Arduino gets the character immediately and then the character is saved in the Arduino memory and then another three characters need to be entered to write the password into the system. and then you can change that password to your current password

FLOW CHART - We can see in the flow chart that the command given to the microcontroller is as follows: first we need to enter the password then condition check first that the entered password is correct or wrong. If the entered password is correct then display will show us that “PASSWORD IS CORRECT” or entered password is incorrect then display will show us that “PASSWORD IS INCORRECT” if password is correct then door will open for that person.

We can see in the flow chart that the command given to the microcontroller is as follows: first we need to enter the password then condition check first that the entered password is correct or wrong. If the entered password is correct then display will show us that “PASSWORD IS CORRECT” or entered password is incorrect then display will show us that “PASSWORD IS INCORRECT” if password is correct then door will open for that person.

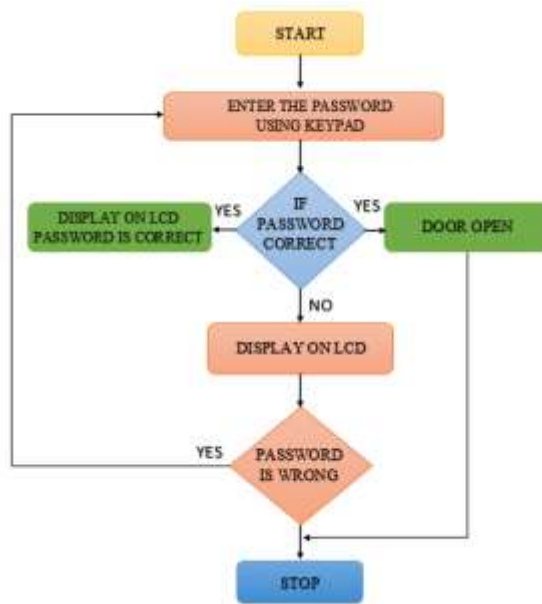

Figure 3: System flow chart

SYSTEM WORKING- First, the project works as a security for our home, office, etc. we will bring power to the arduino, which is the head of our project

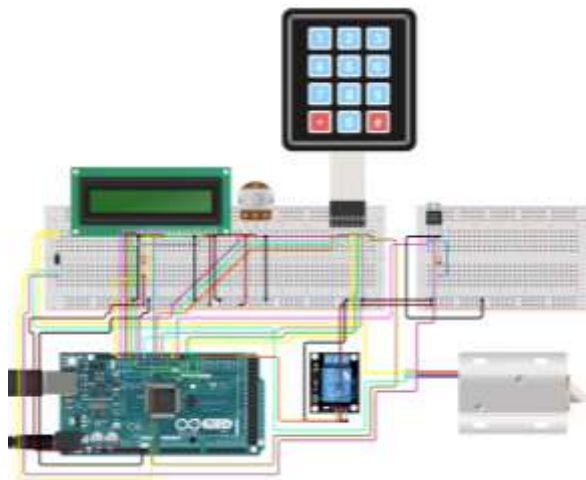

Figure 4: Diagram of Hardware Setup

When 12V power is applied through the circuit, the electromagnetic lock is opened. We must enter the correct 4/5-digit password using the 4*4 matrix keyboard, which we set and give only to an authorized person. Then our processor (arduino) read the code no. if this code is completely correct, it will command the electromagnetic lock to open the door, which is based on the electric magnet, when it is charged with electric current, after which the displaced lock (rod) will move back and the door will open and we can enter or exit the room while the password is right or wrong displayed on this 16*2 LCD display.

This door will automatically close after a few seconds due to the loss of the electrical charge of the lock after some time, which means that we do not have to wait to check whether the door is perfectly locked or not. When we want to cross this door, we must enter the correct password.

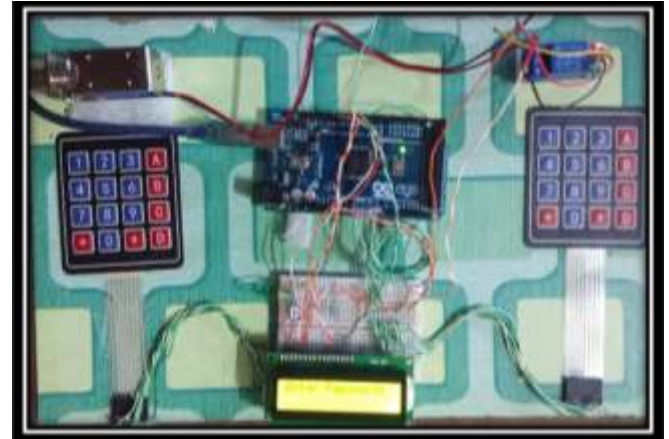

Figure 5: output Before entering the password lock is open (door closed)

If we enter the wrong password, the lock will not open and the display will show that the entered password is wrong. the password we set to open the door we can.

RESULT & DISCUSSION

What we see in the photo is the finished product of this endeavour. The outcomes of our testing of the system's functionality will now be discussed. The lcd screen, relay, and solenoid lock will activate when the power button on the Arduino Uno is pressed. In order to unlock the door, type the password into the lcd's "enter password" prompt. If the code is right, an LCD screen will read "welcome," and the door will unlock. If the erroneous password is entered, the message "wrong password" will be shown and the lock will remain closed. The ability to alter the password is a further useful feature offered by this system. You may access the option to change your password by pressing A and then entering your current one. A security code must be entered when the LCD reads "input old password" and "security code" respectively. Now that you know the old password, you may input the new one to change it.

The complete circuit was handled without a hitch throughout the course of this endeavour. It's only a matter of following the wiring schematic and making sure everything is connected. To pinpoint the origin of the issue, a search was conducted.

There were some software issues with setting up the project to produce the desired results, so we restarted the debugging process in hardware by replacing the failed relay with a brand-new one.

CONCLUSION

In modern society, a solid security system is a must-have. This system was developed to answer the growing need for a more robust security infrastructure in modern times. Automatic door locking systems were developed to facilitate keyless entry. Autonomous systems are on the rise in today's high-tech society, which means that developments in cutting-edge technologies, including the newest automated door lock security systems, are continual and fast. Because safety is now a top priority for everyone, more sophisticated security door lock systems that take use of emerging technology are always being demanded. In the future, we want to replace the keyboard with a biometric scanner and create a more space-efficient configuration for the controller and its accessories.

This project taught them not just how to use software and technology, but also how to get the information they need. This article is to cover door lock security systems in depth.

ACKNOWLEDGMENT

We record our heart-felt gratitude and indebtedness to our guide Dr. UMAKANT GHOATRE. for supervising us care and zeal throughout our project "**PASSWORD PROTECTED DOOR LOCK SECURITY SYSTEM**" We would like to thank principal Dr. Sunil S. Chavan. and Dr. V.P. Patil. (HOD OF EXTC DEPT and Vice Principal) of our prestigious institute for his helpful guidance and encouragement.

We are immensely thankful to all the respected teachers of EXTC Department for the hands to help that they offered to us with affectionate understanding whenever we needed it.

REFERENCES

- [1] *Principle of working computer arduino, abuja, electronic computer and computation (icecco): 11th ieee international conference.*
- [2] *Okaalice o., adigunadebisi a., falohunadeleye s., and alamu f. o., "development-of-programmable electronic digital code lock system", international journal of computer and information technology (issn: 2047679) - issue 01, january 2013.*

- [3] *ashishjadhav, maheshkumbhar, 'feasibility password protected door locking system', international journal of innovative research in computer and communication engineering, vol. 1, issue 6, august 2013.*
- [4] *arpitamishra, siddharthsharma, sachindubey, s.k.dubey, "a password-based security lock system", international journal of advanced technology in engineering and science, volume no.02, issue no. 05, may 2014.*
- [5] *nikhil agarwal, microcontroller based home security system with remote monitoring, department of ec engineering, mit, manipal.*
- [6] *m.faundez zany, the vulnerability of biometric security system, ieee aerospace and electronic system magazine, 2014.*
- [7] *w.durfee, arduino microcontroller guide, university of minnesota, ver-2014.*
- [8] *janaki venukumar, naveen s, arduino based door access control, international journal of research in advent technology, vol.4, no.8, august 2016.*
- [9] *vinay sagar k n, kusuma s m, home automation using internet of things, international research journal of engineering and technology (irjet) volume: 02 issue: 03 jan-2015.*
- [10] *janaki venunumar, naveen s, arduino based door access control, international journal of research advent technology, vol.4, no.8, august 2016.*