

Hawk Eye Radar System

Ishwarlal Rathod¹, Rohit Manna², Ankit Saxena³, Ojas Sharma⁴, Atharva Pednekar⁵

Symbiosis University of Applied Sciences, Indore, Medicaps University Indore (M.P.),

ishwarlal.rathod@suas.ac.in

Received on: 29 March, 2023

Revised on: 17 April, 2023

Published on: 19 April, 2023

Abstract – In recent years, there have been many advancements in RADAR technology and signal processing techniques, leading to new applications beyond traditional uses in defense and space [1][8]. RADAR, short for Radio Detection and Ranging, is a detection system that employs radio waves to identify characteristics of detected objects such as range, height, direction, and speed. In this paper, we present a novel radar system that utilizes ultrasonic sensing technology for non-contact detection of objects [2]. The sensor's movement is controlled by a small servo motor, and an Arduino Uno board is used as the microcontroller for the system.

Keywords -Radar, Ultrasonic sensor, Non-contact technology, Arduino UNO, SONAR

I –INTRODUCTION

The contemporary applications of radar are extremely diverse, encompassing areas such as air traffic control, radar astronomy, air-defense systems, antimissile systems, marine radars for locating landmarks and ships, guided missile target locating systems, and ground-penetrating radar for geological observations [5]. A radar system transmits an electromagnetic pulse through the atmosphere, which will scatter off objects in its path. While most of the energy will be absorbed by these

targets, some of it will be reflected back to the radar, and the scattered radiation will be picked up by the receiver. If multiple targets are present, the scattered signals will combine to form a stronger signal, from which range, position, direction, and altitude can be calculated.

Technically speaking, the project is based on SONAR (Sound Navigation and Ranging) technology, as it employs an ultrasonic sensor to detect objects within a specific range [9]. The ultrasonic transmitter emits a high-frequency sound wave that travels through the air, and when it encounters an object, it reflects back towards the sensor, where the ultrasonic receiver module detects the reflected wave [7].

II -LITERATURE REVIEW

Research and development in radar technology have been immensely successful, leading to significant advancements in computing. Researchers have been working on designing and improving radar systems to enhance security and user interfaces to meet the specific performance requirements in different environments. Radar is an object detection system that utilizes electromagnetic waves to determine the range, altitude, direction, or speed of both stationary and moving objects, including aircraft, ships, motor vehicles, weather formations, and terrain [4]. When ultrasonic waves are used instead of electromagnetic waves, the system is referred to as ultrasonic radar [6]. Ultrasonic sensors, which work on a principle similar to radar or sonar, are

the primary components of ultrasonic radar, and they interpret the echoes from sound waves to evaluate target attributes. The purpose of this project is to use an Ultrasonic Sensor connected to an Arduino UNO board to detect the presence of obstacles in front of the sensor by measuring the signal received from the sensor.

III -COMPONENTS USED

3.1 Arduino UNO

The Arduino UNO is a popular microcontroller board built around the ATmega328P chip. It features 14 digital input/output pins, 6 of which can be used as PWM (Pulse Width Modulation) outputs, and 6 analog inputs. It also includes a 16 MHz ceramic resonator, a USB connection, a power jack, an ICSP (In-Circuit Serial Programming) header, and a reset button. The board provides everything necessary to support the microcontroller, making it easy to get started by connecting it to a computer with a USB cable or powering it with an AC-to-DC adapter or battery.



Fig 1-Arduino uno

3.2 HC-SR04 Ultrasonic Sensor

HC-SR04 distance sensor is commonly used with both microcontroller and microprocessor platforms like Arduino, ARM, PIC, Raspberry Pie, etc. The working principle of the HC-SR04 sensor involves sending out an ultrasonic wave and measuring the time it takes for the wave to bounce back off an object and return to the sensor. This time is directly proportional to the distance between the sensor and the object, and can be calculated by the microcontroller or microprocessor platform to determine the distance.

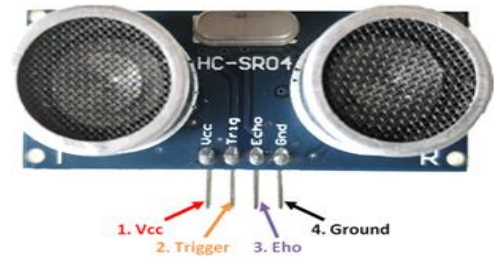

Fig 2-HC-SR04 Ultrasonic Sensor

HC-SR04 Sensor SG-90 Features:

- Operating voltage: +5V
- Theoretical Measuring Distance: 2cm to 450cm
- Practical Measuring Distance: 2cm to 80cm
- Accuracy: 3mm
- Measuring angle covered: <math><15^\circ</math>
- Operating Current: <math><15\text{mA}</math>
- Operating Frequency: 40Hz

3.3 Tower Pro SG-90 Servo Motor

A servo motor is an electronic component designed to provide precise control over the rotation or movement of an object. It can be used to rotate an object to a particular angle or distance with high accuracy.



Fig 3-Servo motor

SG-90 Servo Motor Features:

- Operating Voltage is +5V typically
- Torque: 2.5kg/cm
- Operating speed is 0.1s/60°
- Gear Type: Plastic
- Rotation: 0°-180°
- Weight of motor: 9gm
- Package includes gear horns and screws

Wire Number	Wire Color	Description
1	Brown	Ground wire to be connected to the ground of Arduino.
2	Red	Powers the motor, typically +5V is used.
3	Orange	PWM signal is given in through this wire to drive the motor.

3.4 USB Cable

The USB bus operates within a voltage range of 4.75 to 5.25 volts. While official Uno boards typically feature a USB-B connector, some 3rd party Uno boards may use mini USB or micro USB connectors instead. These cables enable communication between an Arduino board and a computer, as well as allowing for connections to other USB devices such as printers and scanners. USB cables are capable of transmitting data at high speeds with reliable, high-performance data transmission.



Pin Number	Pin Name	Description
1	V _{cc}	The V _{cc} pin powers the sensor, typically 5V.
2	Trigger	The trigger pin is an input pin. This pin has to be kept high for 10μs to initialize measurement by the ultrasonic wave.
3	Echo	The echo pin is an Output pin. This pin goes high for a period of time which will be equal to the time taken for the ultrasonic wave to return to the sensor.
4	Ground	This pin is connected to the Ground of the Arduino.

IV-METHODOLOGY

The hawk eye radar system can be explained with the help of a block as shown in Figure 6 and the circuit

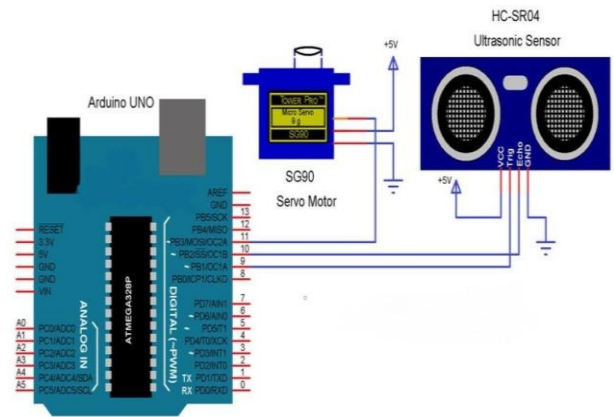

Fig 2-Ultrasonic Radar System

diagram mentioned in Figure 5. The SG90 Servo Motor and the HC-SR04 ultrasonic sensor are connected to the microcontroller through data pins. We will use Arduino due to its easy use. It also provides several digital pins to interface with the Servo motor and ultrasonic sensor at the same time.

HC-SR04 distance sensor is commonly used with both microcontroller and microprocessor platforms like Arduino.

The battery is connected to the servo motor, ultrasonic sensor, and microcontroller board for providing a constant supply. The servo motor is connected to the controller and the battery will only rotate its axle when it gets a signal from the microcontroller.

When the sensor detects any object, it generates a signal and sends it to the microcontroller. The servo motor connected to the controller stops. The program written for the system will allow the servo motor to stop whenever the sensor detects any object.

V- DESIGN

Block Diagram

The block diagram shows the involvement of cloud environment in our research work, so that we can use internet to communicate the detected objects.

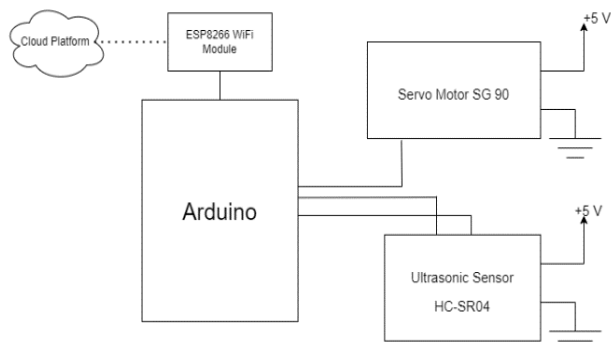

Fig 6-Ultrasonic Radar System Block Diagram

VI -RESULT



Fig 7-Implementation of Ultrasonic Radar System

The proposed system is very much effective for defense purposes. If Hawk Eye Radar System gets implemented on the borders of our country, we can control the illegal intrusions of gunmen, terrorists, spies, incendiaries, etc. Here, Hawk Eye Radar System can be implemented, which on detecting obstacles would fire any missile or something as a response to destroy the obstacle before it reaches the Earth's surface. Well, the same goes for the defense mechanism of a country.

Most prominently, Hawk Eye Radar System can be used for detecting and locating landmines (not visible to the naked eye) and torpedoes underwater. Hence can turn out to be a Savior. If Hawk Eye Radar System gets implemented on the borders of our country, we can control the illegal intrusions of the gunman, terrorists, spies, incendiaries, etc[10].

To avoid Traffic Congestion and escaping traffic signals, Hawk Eye Radar System is a one-stop solution.

FUTURE SCOPE

We can extend our research using the HC-SR04 ultrasonic range sensor connects directly to the

Raspberry Pi's GPIO port so you can detect distances or how close your robot gets to objects as well communicate to the station for control purpose. Similarly, Hawk Eye Radar System can be used for getting the count of several enemies, their positions, and their exact distance from that of us.

REFERENCES

- [1] G. Bhor, P. Bhandari, R. Ghodekar and S. Deshmukh, "Mini Radar," *International Journal of Technical Research and Applications*, pp. 68-71, 2016.
- [2] Z. Khan, J. J. Lehtomäki, R. Vuohtoniemi, E. Hossain and L. A. DaSilva, "On opportunistic spectrum access in radar bands: Lessons learned from measurement of weather radar signals," *IEEE Wireless Communications Magazine*, p. 1-15, 2016.
- [3] J. H. Bungey and S. G. Millard, "Radar inspection of structures," *Proc. Int. Civ. Engineers. Struct. Buildings.*, vol. 99, pp. 173-178, 1993.
- [4] M. M. Golovko and G. P. Pochanin, "Automatic measurement of ground permittivity and automatic detection of object location with GPR images containing a response from a local object," in *Ultrawideband Radar: Applications and Design*, 2012.
- [5] O. Schumann, M. Hahn, J. Dickmann and C. Wöhler, "Semantic segmentation on radar point clouds," *2018 21st International Conference on Information Fusion*, pp. 2179-2186, 2018.
- [6] R. Khan, S. U. Khan, R. Zaheer and S. Khan, "Future internet: The internet of things architecture, possible applications, and key challenges," *Proc. - 10th Int. Conf. Front. Inf. Technol*, p. 257-260, 2012.
- [7] S. A. Hassan and H. Mazhar, "Analysis of target multi-paths in WiFi-based passive radars," *IET Radar, Sonar Navig.*, vol. 10, no. 1, p. 140-145, 2016.
- [8] N. H. A. Aziz and R. S. A. R. Abdullah, "RCS classification on ground moving target using LTE passive bistatic radar," *J. Sci. Res. Dev.*, vol. 3, no. 2, p. 57-61, 2016.
- [9] D. Jayakumar, A. Pravalika and K. P. Rao, "Model Radar Implementation Using Ultrasonic Sensor," 2014.
- [10] P. S. Abhay, S. K. Akhilesh, P. Amrit and Kriti, "A Review on Ultrasonic Radar Sensor for Security system," *Journal of Emerging Technologies and Innovative Research (JETIR)*, pp. 137-140, 2016.