

Stress Analysis of Bolts Failure in Flange Joint of Coiler Drum in Steckel Furnace by Using Fem Methods

P. N. Awachat¹, V.K. Parate², S.S. Jane³

¹Assistant Professor, Department of mechanical engineering G.H.R.A.E.T. Nagpur

²PG student Department of mechanical engineering G.H.R.A.E.T. Nagpur

³Assistant Professor, Department of mechanical engineering COET Akola

Abstract – FEM is the method of very simple & easiest choice in all types of analysis in structural mechanics i.e. solving for deformation and stresses in solid bodies or dynamics of structures & any type of construction either in civil or mechanical field. The most attractive feature of the FEM is its ability to handle complicated geometries and boundaries with relative ease. The steps used in FEM methods are simple & convenient for failure problems of mechanical parts. This paper presents the insight of stress analysis in a bolted joint of Collar Drum in Steckel Mill under load & software is used as ANSYS for the analysis of the mechanical parts to find out its structural analysis. Present work includes finite element approach to study the results of failure of flange joint of Coiler Drum. A three-dimensional finite element model of a bolted joint has been developed using Pro-E wildfire 4.0 and analysis has been done in ANSYS 11 commercial packages. Modeling of Flange joint is done and then Structural analysis has been performed. Results obtained after analysis was then articulated which show good agreement. Finally, critical areas were identified and confirmed with the stress distribution results from simulation. The FEA outputs, such as stress and strain (Deformation), can be used with failure criteria to predict failure. This paper shows the result of Ansys analysis of mechanical parts in figures.

Keywords- Flange joint, Bolts failure, load, Modeling, Stress Analysis ANSYS finite element analysis.

INTRODUCTION

HRM complex Lloyd's steel, Wardhaincorporate a hot rolling mill. The purpose of the hot rolling mill is to convert cast slabs into hot rolled steel, usually by means

of a rolling operation, which may involve either hot tandem or hot reverse rolling. The steckel mill is a single 4-high reversing mill stand. On the ingoing and outgoing sides of the mill stand there are two gas-fired hot coiling steckel furnaces with heated coiler drums onto which the coil is coiled during each successive pass. When the desired steel gauge is reached, after three, five or seven passes, it runs out of the mill stand, via roller tables to the down coiler.

There are two down coilers, i.e. Down Coiler – 2 and Down Coiler-3. Down Coiler – I were shut down since past one and half year. The capacity of D.C-I was 18 ton and its specifications was same as that of D.C-2. Following table shows the comparison between D.C-2 and D.C-3.

Table -1

Sr.No	Characteristics	D.C – 2	D.C-3
a)	Capacity	18	22
b)	Rolls	Wrapper roll & Pinch roll	Wrapper roll & Pinch roll
c)	Pushing mechanism	Hydraulic DC valves	Servo valves
d)	Mandrel	Single expand & collapse, Bean shape links for expand and collapse for Inner diameter tightening.	Double expand & collapse, wedge type expand and collapse for inner diameter tightening.
e)	Max. Expansion	25 mm	50 mm

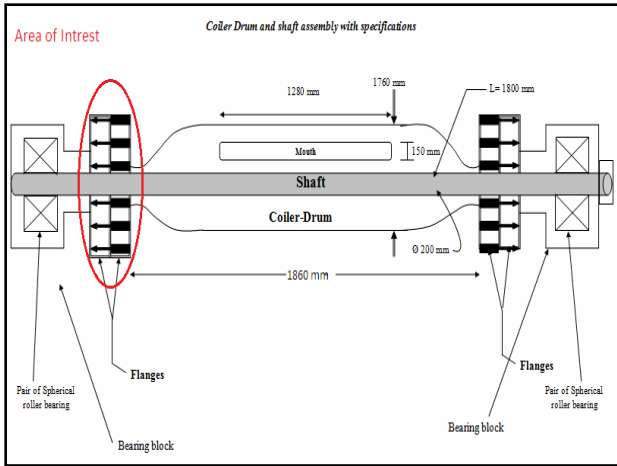

Fig 1-Specifications of Coiler Drum system.

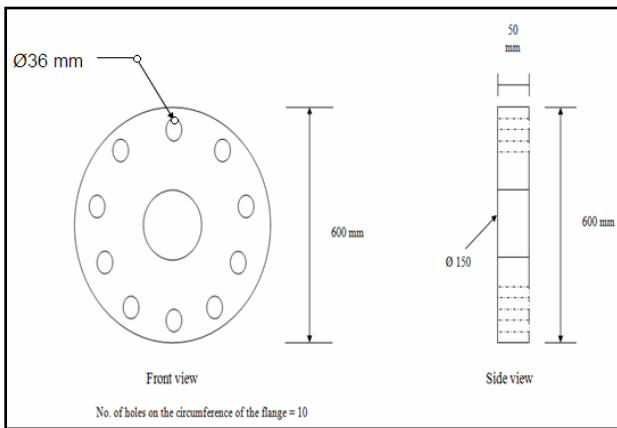

Fig 2-Specifications of Flange

II. PROBLEM IDENTIFICATION

Problem Origin: Reversible Finishing Mill (Steckel Furnace): The coiler-drum is an essential component of steckel mill reversing hot strip rolling process. A steckel mill produces hot rolled strip steel from cast slab which are heated before being converted via roughing to the transfer bar of which the thickness is subsequently reduced (up to 1.8 mm) to the desired gauge by means of a reverse rolling process performed by the steckel mill. Coiler drums are located inside two steckel furnaces which are positioned on the both sides of the mill stand. As the strip thickness is reduced during each pass, length increases. In order to obtain high rolling speed and retain temperature, the strip is successively coiled and uncoiled, under tension onto and from the heated coiler drum during processing. Since from the installation of Reversible finishing mill both the Down Coilers have maximum capacity of 18 tons, i.e. D.C-I and D.C-2. After the shutdown of D.C-I, D.C-3 was installed which was having the maximum capacity of 22 tons. Since the net load is increased by 4 tons the factor of safety is not sufficient to avoid frequency of failure of flange joint

which increased subsequently. Thus, the frequency of failure of flange joint increases after the incorporation of D.C-3 as production capacity increases by 4 ton, causes breakdowns as there is breakdown maintenance approach. Bolted flange joint is made up of Coiler Drum Shaft's fixed flange fastened with on-board bearing flange by Nuts-bolts. As the magnitude of load changes with respect to time thus causes whirling & positive bending moment of the shaft. Relative stresses have been increased. Along with the high temperature about 9500c, thermal stress plays important role in failure of flange joint. Due to high temperature and load, the stresses are induced per cycle inside the bolt via flanges causes shearing of bolt head. Moreover, a bolted joint is one of the joining techniques employed to hold two or more parts together by the help of nut and bolt to form an assembly in mechanical structures. The flange joint consist of two flanges joined with 10 Nut-bolts.

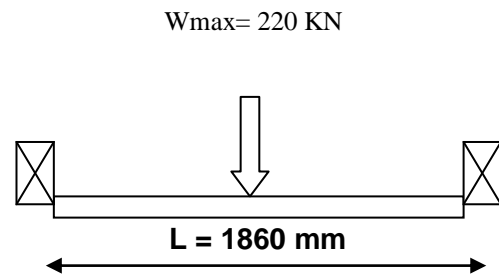

Fig 3-Simply supported Beam (Shaft)

$$\begin{aligned} \text{Load acting on one flange} &= W/2 \\ W/2 &= 220/2 = 110 \text{ KN} = 110000 \text{ N} \\ \text{Direct load acting on one bolt} &= 110 \text{ KN}/10 \\ &= 11 \text{ KN} = 11000 \text{ N} \end{aligned}$$

II.REVIEW

The coiler-drum is an essential component of steckel mill reversing hot strip rolling process. A steckel mill produces hot rolled strip steel from cast slab which are heated before being converted via roughing to the transfer bar of which the thickness is subsequently reduced to the desired gauge by means of a reverse rolling process performed by the steckel mill. Coiler drums are located inside two steckel furnaces which are positioned on the both sides of the mill stand. As the strip thickness is reduced during each pass, length increases. In order to obtain high rolling speed and retain temperature, the strip is successively coiled and uncoiled, under tension onto and from the heated coiler drum during process [12]. Due to high temperature and load, the stresses are induced per cycle inside the bolt via flanges causes shearing of bolt head. Moreover, a bolted joint is one of the joining techniques employed to hold two or more parts together by the help of nut and bolt to

form an assembly in mechanical structures [1]. The flange joint consist of two flanges joined with 10 Nut-bolts as shown in fig.2. It is a joint between coiler drum flange and on-board bearing flange and fastened with nuts and bolts.. As bolts and flange are subjected to load of 22 tons, resulting into cyclic fatigue and shearing of bolt head and sometimes at the interface. Fig.3 gives clear idea of cross section of Steckel Mill. Kovács et al. [2] carried out an experimental study on the behaviour of bolted composite joints. The composite base columns were investigated under cyclic loading. Su and Siu [3] analyzed the nonlinear response of a bolt group under in-plane loading using the numerical method. In order to predict the physical behaviours of the structure with a bolted joint, simulation with three dimensional finite element models is desirable. With the recent increase in computing power, three dimensional finite element modeling of a bolted joint in bending has become feasible. T. N. Chakherlou, M. J. Razavi, A. B. Aghdam [4] carried out the study of variation of bending force and its concomitant effects on the performance of bolted double lap joints subjected to longitudinal loading. The results unanimously revealed a gradual initial reduction of bending force followed by a significant increase as the longitudinal load was increased. Also affected, was the load transfer mechanism in the joint resulting in variation of friction force between the flanges, but in a different trend compared to bending force.

Maggi et al. [11] also demonstrated using the same software how variations of geometric characteristics in bolted end flange could change the connection. Investigation on failure of threaded fasteners due to vibration spans nearly sixty years. Sparling [5] found that the fatigue life of the bolt could be amplified appreciably by tapering the nut thread form for the first few engaged threads measured from the loaded face of the nut. It also stated that truncating the threads improved fatigue life but reduced the static load capacity. Nevertheless, experimental studies in the late 1960s by Junker [6] demonstrated that loosening and failure both becomes more rigorous when the joint is subjected to dynamic loads perpendicular to the thread axis (shear loading). The most extensively used apparatus for experimental study of loosening under dynamic shear load is the transverse vibration test apparatus developed by Junker [6].

III. Failure of bolt in flange joint

Sometimes, the bolts are used to prevent the relative movement of two or more parts, as in case of flange coupling, and then the shear stress is induced in the bolts. The shear stresses should be avoided as far as

possible. It should be noted that when the bolts are subjected to direct shearing loads, they should be located in such way that the shearing load comes upon the body (i.e. shank) of the bolt and not upon the threaded portion. In some cases, the bolts may be relieved of shear load by using shear pins. When a number of bolts are used to share the shearing load, the finishing bolts should be fitted to the reamed holes.

Let,

D= Major diameter of the bolt

Dc = Core diameter of bolt

p= pitch of bolt

n= Number of bolts = 10

τ = Shear stress

For M36 x 4 with p= 4 mm

D = 36 mm

Dc =31.093 mm

Shearing load carried by the bolt,

$$P = \pi/4 \times Dc^2 \times \tau \times n$$

$$110000 = \pi/4 (31.093)^2 \times \tau \times 10$$

$$\tau = 14.487 \text{ N/mm}^2$$

$$\tau = 14.487/125 \text{ N/mm}^2 \text{ per mm length of bolt}$$

$$\tau = 0.1158 \text{ N/mm}^2 \text{ per mm length of bolt}$$

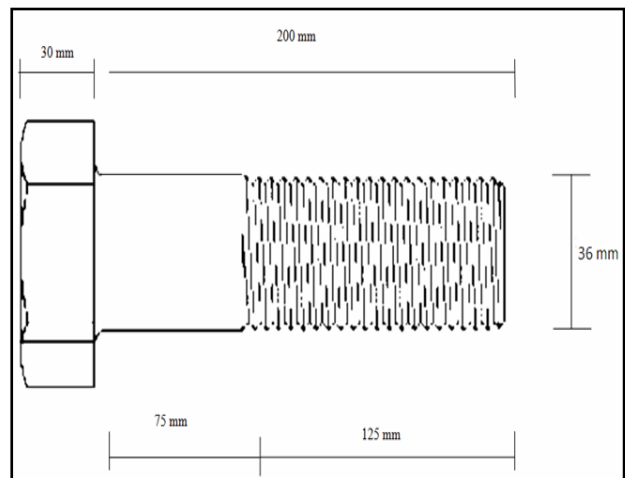

For M36 x 3 with p=3 mm

D = 36 mm

Dc = 32.219 mm

$$\tau = 13.408 \text{ N/mm}^2$$

$$\tau = 13.408/125 \text{ N/mm}^2 \text{ per mm length of bolt where the length under shear} = 125 \text{ mm}$$

$$\tau = 0.1073 \text{ N/mm}^2 \text{ per mm length of bolt}$$

BOLTS OF UNIFORM STRENGTH :

Mainly the load applied to the bolt acts on the weakest part of the bolt i.e. cross sectional area at the threaded portion. In other word , the stress in the threaded will be higher than that in the shank .Hence a great portion of the energy will be absorbed at the region of the threaded

part which may fracture the threaded portion because of its small length. In this method ,an axial hole is drilled through the head as far as the thread portion such that the area of the shank becomes equal to the root area of the thread.

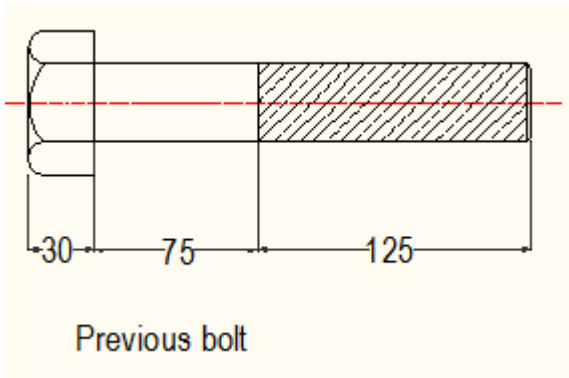

Let,

D = Diameter of the hole.

Do = Outer diameter of the thread

Dc = Core diameter of the thread.

Using this method we get,

$$\pi/4 \times D^2 = \pi/4 \times (Do^2 - Dc^2)$$

$$D^2 = Do^2 - Dc^2$$

$$D = \sqrt{(Do^2 - Dc^2)}$$

$$= \sqrt{(36^2 - 31.093^2)}$$

$$= 18.1445 \text{ mm}$$

Considering shank portion under shear, the shear stress using bolt of uniform strength method is given by relation,

$$P = \pi/4 \times (Do^2 - D^2) \times \tau \times n$$

$$110000 = \tau \times \pi/4 \times (36^2 - 18.1445^2) \times 10$$

$$\tau = 14.487 \text{ N/mm}^2$$

$$\tau = 14.487 / (125 + 75) \text{ N/mm}^2 \text{ per mm length of bolt}$$

$$\text{where the length under shear} = 125 + 75 = 200 \text{ mm}$$

$$\tau = 0.072 \text{ N/mm}^2 \text{ per mm length of bolt}$$

From this we find that after using the method of bolts of uniform strength, the maximum shear stress induced in bolts remains same for the total length, but it is reduced per mm length of bolt

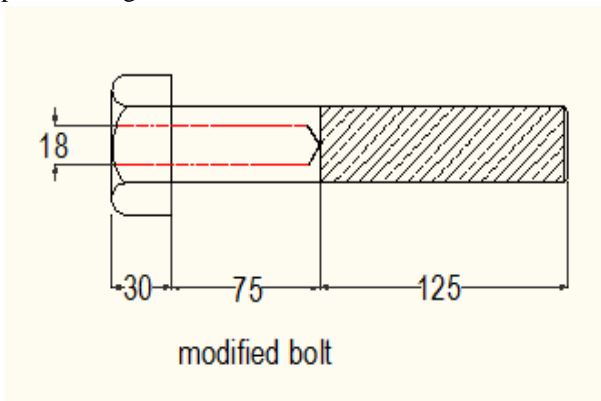

Research Methods

FEM is used as the research methods for the purpose of analysis of the failure of stress analysis of bolts failure in flange joint of coiler drum in steckel furnace. The following,

Images are represents for the FEM analysis the following figure of mechanical part of bolts are analysis by ANSYS softer. The flange joint with all nut & bolts also with coupling are analysis & represent in the following figures.

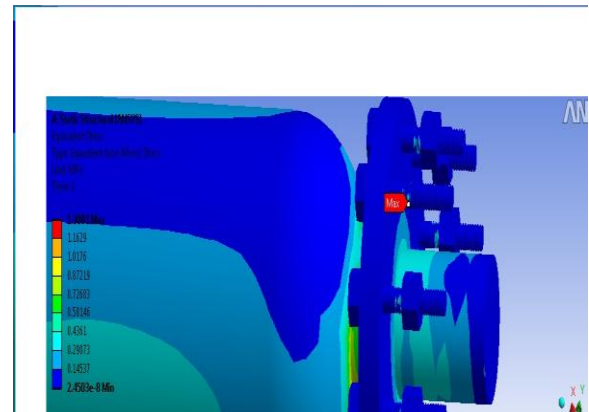

Fig.-4-FEM Analysis

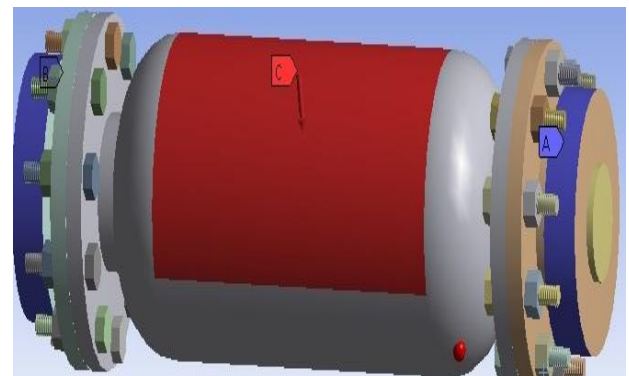

Fig. -5 FEM Analyses

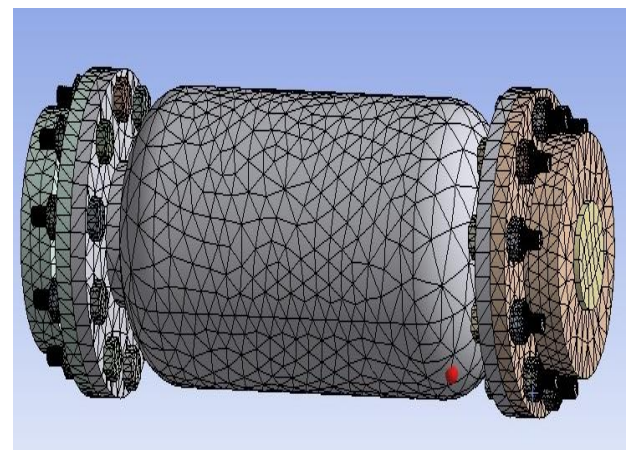

Fig. -6FEA Analysis

CONCLUSION

The failure of bolts in flange joint of coiler drum of steckel furnace is mainly due to the shear stress induced in the bolts. The shear stress induced can be reduced slightly by using M36 x 3 bolt instead of M36 x 4. Also using the method of bolt of uniform strength the maximum shear stress is not reduced but the length of bolt under shear is increased which in turn causes the shear stress per unit length to reduce.

REFERENCES

- [1] Aidy Ali*, Ting Wei Yao, Nuraini Abdul Aziz, Muhammad Yunin Hassan and Barkawi Sahari, Simulation and
- [2] Kovács, N., Calado, L., and Dunai, L. (2004). Behavior of bolted composite joints: experimental study. *Construction Steel Research*, 60(3-5):725-738.
- [3] Ju, S.H., Fan, C.Y., and Wu, G.H. (2004). Three dimensional finite elements of steel bolted connections. *Engineering Structures*, 26(3):403-413.
- [4] T. N. Chakherlou, M. J. Razavi and A. B. Aghdam (2011). On the Variation of Bending Force in Bolted Double Lap Joints Subjected to Longitudinal Loading: A Numerical and Experimental Investigation. *Journal for Experimental Mechanics*, 10.1111/j.1475-13.05.2010.00795. X
- [5] SPARLING, L. G. M., 'Improving the strength of Nut fasteners', *Chart. Mech. Engr*, April 1982, 58-59.
- [6] JUNKER GH. New criteria for self-loosening of fasteners under vibration. *SAE Transactions* 1969; 78:314-35.
- [7] D. Lehmann, Nonlinear axis force and bending moment distribution in bolt clamped L-flange, *Stahlbau* 9 (2003) 653-663 (in German).
- [8] Gambrell SC. *Why bolts loosen* (Machine Design 1968; 40:163-7)
- [9] Krishnamurthy N. Fresh look at bolted end-flange behavior and design. *Engineering Journal, American Institute of Steel Construction* 1978; 15(2):39-49 (second quarter).
- [10] Krishnamurthy N, Krishna VR. Behavior of splice-flange connections with multiple bolt rows. Report submitted to the Metal Building Manufacturers Association; February 1981.
- [11] Y.I. Maggi, R.M. Conclves, R.T. Leon, L.F.L. Ribeiro, Parametric analysis of steel bolted end flange connections using finite element modeling, *J Construct. Steel Res.* 61 (2005) 689-708.
- [12] Gert J.M. Hamman, An investigation of Steckel mill coiler drum failure mechanisms, University of Johansburg, Nov 2006.
- [13] Jeong Kim, Joo-Cheol Yoon, Beom-Soo Kang, "Finite element analysis and modeling of structure with bolted joints", *Applied Mathematical Modeling* 31 (2007) 895-911.