

Performance Analysis of Z Source Inverter Fed Induction Motor Drive Open Loop System using MATLAB Simulink

Shweta D. Bhujade¹, Diksha Khare², Rajendra Bhombe³, Dr. Kishor B. Porate⁴

¹M.Tech Student, ^{2,3}Assistant Professor, ⁴Associate Professor

Department of Electrical Engineering, Guru Nanak Institute of Engineering and Technology, Nagpur, Maharashtra, India, 441501

Email of corresponding Author: swetabhujade@gmail.com

Received on: 05 March, 2025

Revised on: 03 April, 2025

Published on: 05 April, 2025

Abstract – The use of induction motors have been increasing greatly since the day of its development. The reason for its day by day increasing reputation can be primarily attributed to its robust construction, simplicity in design and cost effectiveness. They are being used in robotics, domestic and other applications. So, for wide range of use in the industry, the machine requires an efficient drive circuit arrangement. Currently, conventional voltage source inverter (VSI) or current source inverter (CSI) is dealing as key part in the field of induction motor drive circuit. These inverters fail to perform at our desire level due to some crucial drawbacks. In this project the drawbacks of traditional inverters are eliminated by replacing it with Z –Source inverter (ZSI). This project is mainly focused on effective control of induction motor with Z–Source inverter (ZSI).

Keywords- VSI fed IM drive, Z-source Inverter, Controllers, Torque ripples, Stator and Rotor Current, Rotor Speed

I- INTRODUCTION

Conventional converter topologies such as voltage source inverter (VSI) and current source inverter (CSI) are commonly used as power electronics circuits for

power conversion purposes. The VSI produces an ac output (after filtering it) which is limited below the dc input voltage, which means that VSI is buck type converter. The buck operation nature of the VSI limits its operation to power conversion applications and ac drive circuits. An additional dc-dc unit is connected to the dc input of the converter in order to further increase the dc input voltage, which leads to an increase in the ac output voltage. As a result, the additional dc-dc boost converter increases the system cost, control complexity and reduces the efficiency. Further, animism-gating of the inverter bridge switches cause short circuit and destroys the power switching devices. For that, a dead-time is set between the upper and the lower switching devices of the same leg in order to avoid short circuit occurrences. The idea of impedance-source converter (ZSI) was originally developed due to the limitation in VSIs and CSIs. The conceptual and theoretical limitations in the conventional converters types reduce their application and complicate their control methods. While the ZSI great advantage can be seen as: it can operate as VSI inverter (buck type) or as CSI inverter (boost type) depending on the application. The output voltage can ideally ranges from zero to infinity. Since the invention of the ZSI inverter, there are number of research works on this interesting topology,

and this project presents its basic operation and control. The limitations of traditional converter are:

- The capability of traditional converter is only used as buck converter or boost converter.
- Efficiency lower down where over drive is required
- Two thyristors cannot be gated ON in the same leg
- Only 8 switching states are available in traditional converter.
- Either capacitor or inductor available for energy storage and suppress ripples.

The Z-source inverter mainly used the shoot-through states to boost the dc bus voltage for the turning ON two thyristors of the upper and lower phase same leg. As a result the Z-source inverter can buck and boost voltage to a wanted output voltage that is more than dc bus voltage. Therefore improve the reliability of an inverter, the shoot-through cannot occurs to burnout the circuit. The advantages of ZSI has a low-cost, reliable and highly efficient single-stage structure for boost and buck power conversion. The main structure of the Z-source inverter is presented in Fig 1. The maximum constant boost control can greatly reduce the L and C requirements of the Z-source impedance network.

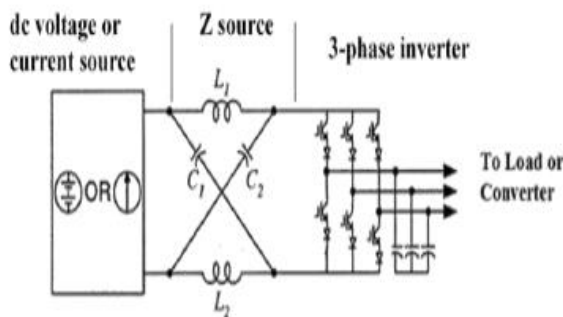

Fig 1: Structure of ZSI

The purpose of this work is to investigate modeling and simulation of a single phase Z-source inverter and its control strategy for implementation dc-to-ac power conversion. The research motivation for this thesis also comes from the necessity of maximum power point tracking (MPPT) for the solar PV panels. The Z-source inverter and its control system should be capable of tracking individual maximum power point of the solar panels and ensures the maximum capture of energy on DC

side. The ZSI impedance network has a unique LC network which is connect with dc link and controller to provide optimal output ac voltage. Also, a comparative performance analysis of a ZSI and VSI which is fed by a PV source is carried out using characteristics and torque.

II- LITERATURE SURVEY

The Z-source inverter has been recognized for its potential in electric motor drives, yet most research has focused on traditional modulation techniques like sinusoidal and space vector pulse width modulation (PWM). The exploration of random pulse width modulation (RPWM) remains limited, despite its advantages in reducing harmonics and improving performance through the use of pseudorandom binary sequences and triangular carrier waveforms. This paper addresses this gap by analyzing the performance of a three-phase induction motor fed by a ZSI operating under RPWM, contributing valuable insights into its operational benefits and efficiency improvements [1].

This paper deals with the comparison of Z-source inverter based control systems for the Asynchronous drive of gas compressor that is used in oil and gas industry. The relevance of the Task is highlighted by the fact that choice of control system determines the reliability and the Efficiency of gas system drive. Two types of indirect DC-link voltage control techniques were examined in order to estimate operation effectiveness of control system in dynamic modes. For that purpose, simulation model of ZSI fed by induction motor, based on state space averaged modeling method, has been developed utilizing MATLAB/Simulink environment. The simulation results of dynamic performance of the ZSI with single-loop and dual-loop capacitor voltage control techniques during input voltage changes and steady state operations are presented and analyzed [2].

The traditional Z-source inverter suffers from large voltage stress across the switches and Discontinuous source current, which is not appropriate for the electric motor and drives applications. This paper presents a design and thorough analysis of a trans-Z-source (transformer-based Z- Source) with higher boost capability and negligible leakage inductance which overcomes the Drawbacks of traditional Z-source inverters (ZSI). Additionally, the fault-tolerant capability of the proposed trans-ZSI is investigated for open-circuit and short- circuit faults occurring in the power

Semiconductor switches of the inverter module. It proposes a highly efficient faulty leg Identification method which is independent of the temperature rise occurring due to high current in the faulty mode. The proposed fault- tolerant scheme is characterized by low cost, fast fault diagnosis irrespective of load and maintaining post-fault speed characteristics of motor identical to pre-fault characteristics. The experimental results are presented to validate the effectiveness of the proposed method for induction motor drives. Also, a comparative study with similar fault diagnosis strategies is tabulated to validate the potential of the proposed fault-tolerant strategy [3].

Impedance Source Inverters are extremely popular these days. They offer simultaneous boosting of input voltage applied as well as inversion operation. The converter achieves this by means of a specially designed impedance network along with H - Bridge. Unlike conventional H – Bridge (HB) inverters, impedance source inverters can boost the supply voltage thereby achieving boost Operation. Utilizing this feature, voltage transient due to grid Side disturbance, improved control and enhanced fault tolerance capability can be achieved. There are two types of impedance source-based inverters namely Z Source Inverters and Quasi Z Source Inverters (qZSI). In this paper, five phase qZSI fed five phase induction motor drive is discussed. V/f control is implemented to induction motor in synchronism with closed loop voltage control of quasi network output voltage. Constraints in the integrated performance are discussed and taken into consideration for development of control algorithm [4].

III- METHODOLOGY OF PROJECT WORK (ZSI FED INDUCTION MOTOR DRIVE)

- Study of basic concepts of Induction motor
- Study of basic concepts of Z- source Inverter.
- Finding the problems from conventional system by surveying literature.
- Analysis of the proposed topology.
- Study of the control strategies of system.
- Design VSI fed induction motor device.
- Simulation of the model can be done in MATLAB software.
- Evaluation of the performance

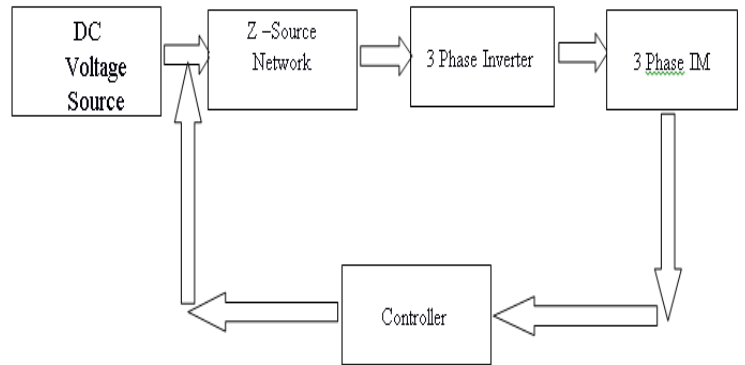

The proposed work is planned to be carried out in the following manner and its block diagram shows in Fig 2.

Fig 2: Block Diagram of Z-Source Inverter fed Induction Motor drive with Controller

The power circuit configuration of the Z-source inverter fed induction motor drive system. Similar to that of a traditional inverter fed induction motor system. The Z-source inverter fed induction motor drive system’s power circuit consists of four major parts: a front end DC source, Z-network, an inverter bridge and a three phase induction motor load as given in Fig 3. The differences are that a DC link circuit is implemented by the Z-source network (C1, C2, L1 and L2).

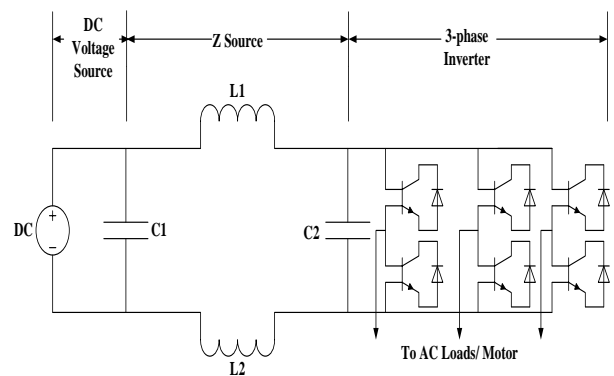

Fig 3: Structure of Z-Source inverter

Induction Motor Rating: The motor used is 3- phase Star Connected Induction motor, Rotor type- Squirrel cage, with the rating as – [4 Pole, 20 HP, 15 KW, 400V, 50HZ, 1460 RPM] as given in Table 1.

Table 1: Specification of Induction motor used as load in the practical circuit

Sr. No	PARAMETERS	RATING
1	Stator Resistance [R_s]	0.1247 Ω
2	Rotor Resistance [R_r]	0.2205 Ω
3	Stator Leakage Inductance [L_{1s}]	0.991 mH
4	Rotor Leakage Inductance [L_{1r}]	0.991 mH
5	Rotor Leakage Inductance [L_M]	64.19 mH
6	Stator Reactance [X_s]	0.31133 Ω
7	Rotor Reactance [X_r]	0.31133 Ω

IV- SIMULATION

This MATLAB simulation model represents the control of an induction motor (IM) drive using two different inverter topologies: a conventional Voltage Source Inverter (VSI) in Fig 4 and an Open Z-Source Inverter (ZSI) in Fig 5. The VSI converts a DC input into a three-phase AC output, providing variable voltage and frequency for efficient speed and torque control. In contrast, the Open ZSI incorporates an impedance network (inductors and capacitors) to enable voltage boosting, eliminating the need for a separate DC-DC converter while enhancing performance and efficiency. Both models demonstrate the effectiveness of these inverter configurations in driving an induction motor under varying load conditions.

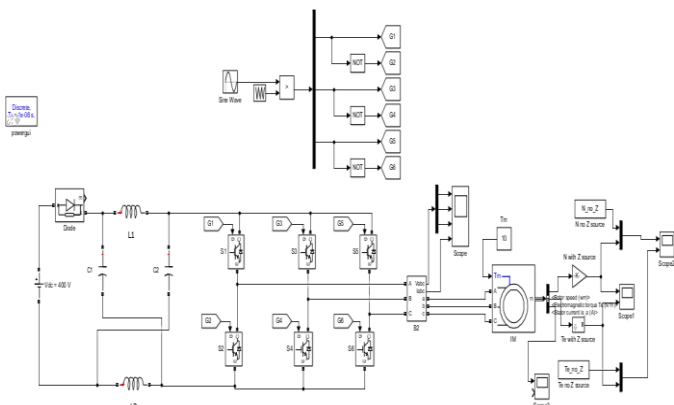

Fig 4: Matlab simulation model of voltage source inverter IM drive

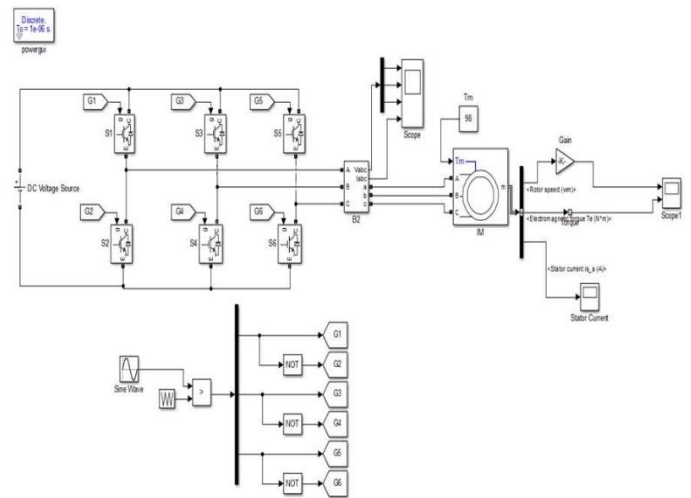

Fig 5: Matlab simulation model of open Z-source fed IM drive

V- RESULT

A. Matlab simulation result Of VSI Fed IM Drive:

Stator Current has been represented in Fig 6, Three-phase PWM current waveforms observed. Voltage waveform has modulated pulses due to PWM switching. Rotor Current has been showed that how initial transients and stabilizes after a few cycles and determines starting behavior and torque ripples. In Fig 7, Rotor Speed: Initially rises from zero and stabilizes at a steady-state value. Under load variations, minor fluctuations occur due to slip

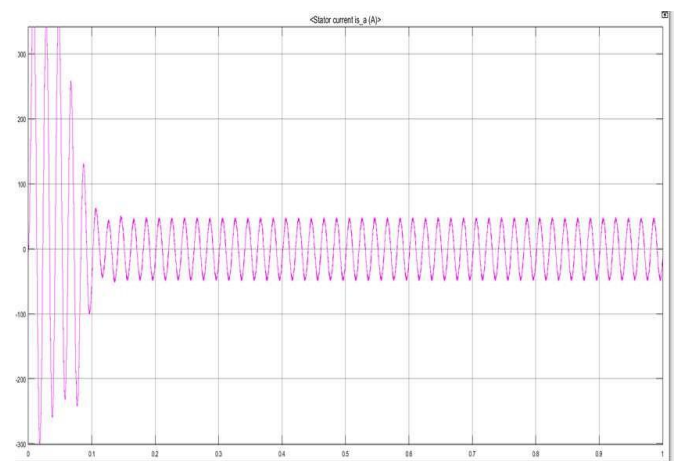

Fig 6: Performance characteristics of Stator Current

$I_{peak} = 37 \text{ A}$, $I_{rms} = 25.4713 \text{ A}$

but are regulated effectively. Electromagnetic Torque: High starting torque is observed, which settles as the motor reaches steady-state. VSI introduces some torque ripple.

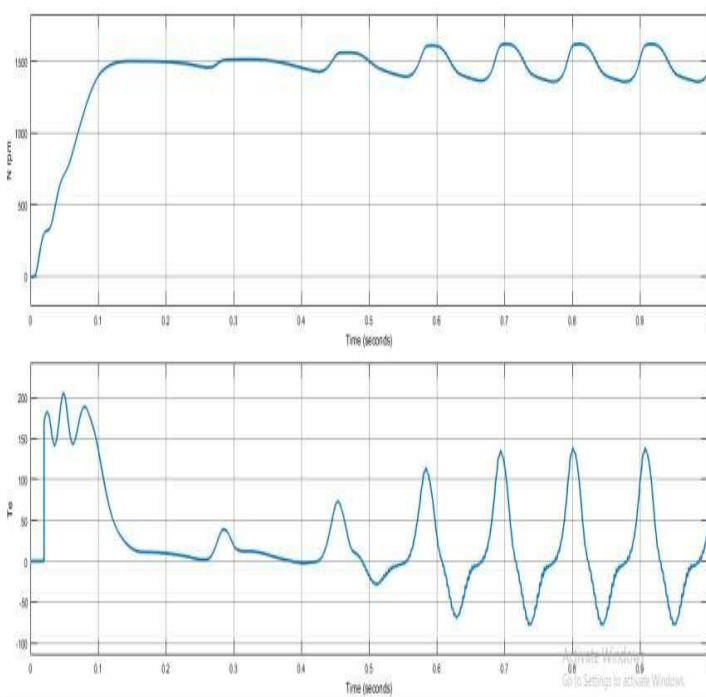

Fig 7: Performance characteristics of Rotor Speed & Electromagnetic Torque VSI fed

Speed vs. Time Response: Smooth acceleration to rated speed. Settling time and steady-state speed analyzed. Torque vs. Time Response: High starting torque with oscillations. Torque ripples reduce in steady state.

B. Matlab Simulation Result Comparative Result With and Without Z Source Inverter:

From Fig 8, the following results have been simplified:

- Voltage Boost: VSI provides fixed output, while ZSI boosts voltage using an impedance network.
- Rotor Speed: ZSI enables faster acceleration and better speed regulation.
- Electromagnetic Torque: ZSI delivers higher torque with reduced ripple.
- Harmonic Distortion (THD): Lower in ZSI, improving efficiency and performance.
- Overall Efficiency: ZSI outperforms VSI by enhancing voltage utilization and reducing losses.
- ZSI significantly improves motor performance, making it a superior choice over VSI drive.

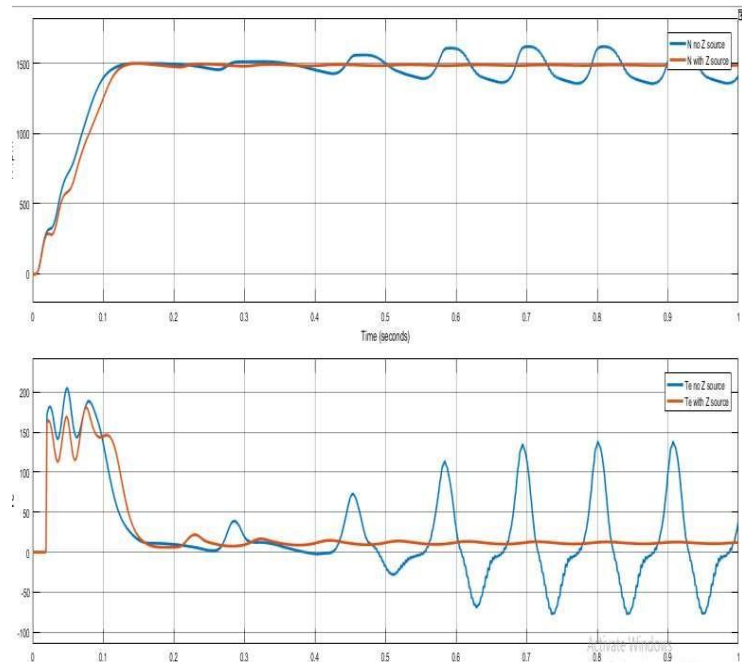

Fig 8: Performance characteristics of Rotor Speed and Torque with Z source and without Z source

VI- CONCLUSION

Z source inverter system and Voltage Source inverter fed induction motor system is explained in details. Limitation of convectional converter and advantages of ZSI are also listed and explained. The ZSI fed induction motor drive and VSI fed Induction motor drive using MATLAB Simulink and result discussed. From the observations, it can be concluded that the Z source inverter fed induction motor drive has better settling time, less torque ripples, improved stator and rotor current for the same load and speed as compared to the Voltage Source inverter fed induction motor drive.

REFERENCES

[1] S. Bhuvanasundaram, Y. Vagapov, A. Anuchin and C. Belloc, "Performance analysis of Z-source inverter operating under random PWM," *IEEE 50th International Universities Power Engineering Conference (UPEC), Stoke on Trent, UK, pp. 1-4, 2015*

[2] Basanti Bhagat, Gurpreet Singh, "Performance and Evaluation of Voltage Source Inverter Fed Induction Motor Drive", *International Research Journal of Engineering and Technology (IRJET), Vol. 6, Issue 2, Feb 2019.*

[3] Anant Thakur, "Z-Source Inverter Fed Asynchronous Motor Drive", *International Journal of Trend in Scientific Research and Development (IJTSRD), Vol. 4, Issue 1, December 2019.*

- [4] R. Malathi , M. Rathina Kumar,R.Gobi , “ Closed loop Control Of ZSI Fed Induction Motor Drive Using PI And Fuzzy Logic Controllers”, *International Journal for Research in Engineering Application and Management (IJREAM) ISSN : 2454-9150, Vol. 4, Issue 6 , September 2018.*
- [5] P.C. Loh, D.M. Vilathgamuwa, Y.S. Lai, G.T. Chua and Y. Li, "Pulse-width modulation of Z-source inverters", *IEEE Transactions on Power Electronics*, vol. 20, no. 6, pp. 1346-1355, Nov. 2005.
- [6] R.Kapil, Dr.Vijayaragavan, “Z-Source Inverter Fed Three Phase Induction Motor Drive with PI and PID Controlled closed loop systems”, *International Journal of Advanced Research in Electrical, Electronics and Instrumentation Engineering (IJAREEIE)*, Vol. 6, Issue 10 , October 2017.
- [7] Mahima Sharma, Mahendra Lalwani, “Performance Evaluation of Three-Phase Induction Motor Drive Fed from Z-Source Inverter”, *International Journal of Applied Engineering Research*, Volume 13, 2018.